

Ahozko hizkuntza :

trukatu, adierazi, ulertu

- Taldeko elkarrizketan parte hartu, bakoitzak bere aldia igurikatuz, besteak entzunez, eta bere burua ulertaraziz.
- Irakasleak kontatzen duen ipuina ulertu eta berriz kontatu.
- Ipuina berriz kontatu lotura logikoei eta kronologiari jarraikiz.
- Hiztegi berezia memorizatu.

Munduaren ezagutza :

- Beldarraren bilakaeraren urratsak ezagutu.
- Asteko egunen segida gogoan hartu.
- Egun bakoitzari ikur bat eman, etxean cir ikaswolan den adierazteko.
- Asteko egunen egutegia eraiki.

Irakurketa :

- Irakurle gaitasunak garatu : ipuinaren eta idatziaren arteko loturaz ohartu.
- Ipuin ezberdinetako irudiak ezagutu eta bereizi.
- Izenburua ezagutu, informazioen xerkatzen jakin.
- Hitzak ezagutu eta gogoan hartu.
- Hitzen behatzeko, erkatzeko eta analizatzeko gaitasuna garatu.
- Ipuinaren sekuentzien segida gogoan hartu.
- Erranaldiaren erran-nahia errespetatu.
- Erranaldian, hitzen lekua kokatu.
- Hitzen arteko lotura egin : eguna, fruitua, zenbakia.
- Erranaldi bat eraiki, hitzak ezkerretik eskuinera ezarriz.
- Erranaldia berriz irakurri, ahozkoaren eta idatziaren arteko lotura eginez.

Matematikak :

- Espazioaren egituratzen ikasi : irakurketa norabidea (ezkerretik eskuinera).
- Errepikatzen den segida bat eraiki.
- Bi ezaugarri kontuan hartu : kolorea eta kopurua.
- Talde jokoetan hasi : bat bateko lotura egin zenbakien eta laukituen artean.
- Bi sartzeko taula irakurri eta hartan kokatu.
- Ardatz batekiko simetriari jarraiki.
- Eremu hetsi bat egituratu.
- Norabidea : plano batean kokatu, lateralitatea landu.
- "Aitzinean", "gibelean", "artean" nozioak ulertu.
- "Eskuin" eta "ezker" bereizten hasi.
- Bildumak eraiki eta erkatu : gehiago, gutiago ; guti, anitz.
- Kopuru baten zifrazko adierazpena ezagutu.

Alfabetoa :

- Letrak ezagutu eta izendatu.
- Hitzen ortografiari ohartu. Letren lekua identifikatu bata beseen arabera.
- Soinu disriminazioa landu : hitzetan soinuak ezagutu.
- Fonemaren eta grafemaren arteko lotura egin.
- Hitz batean silaba bat atzeman.
- Hitzen hastapen eta bukaera ezagutu.
- Hitzen memorizazioa garatu, haien itxura ezagutzuz.
- Letren itxurari behatu.

Grafismoa

- Motrizitate fina garatu.
- Grafismo modelo ezberdinak berregin : borobilak, kakoak, espirala, titak, marra luzeak, etab.
- Marren zentzuari jarraiki.
- Idatz tresna ongi atxiki.
- Lan xehe bat egin.

- Zenbakien segida ezagutu eta bata besteen arabera kokatzen jakin.
- 5 zenbakia ezagutu : batuketa ezberdinak atzeman eta gogoz ikasi.
- Gauzakien luzetasuna eta loditasuna erkatu eta horren arabera sailkatu.
- Batuketa eta kenketa sinpleak egin.

Artegitza :

- Idatziaren funtzioa ulertu liburu bat eraikiz.
- Jestua ekaiari egokitu.
- Irudi batetik abiatuz, teknika bat atzeman eta erabili (drawing gum). Obra bat eraiki urratsez urrats.
- Fruituetan ziloak egin.
- Beldarraren itxuratzeko borobilak txantilo gisa baliatu.
- Perlak baliatuz, beldarrak eraiki.

udarea

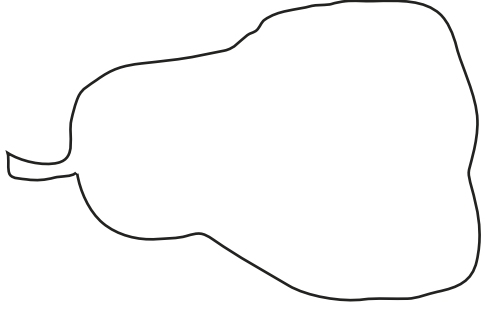

--	--	--	--	--	--	--

Beldarna

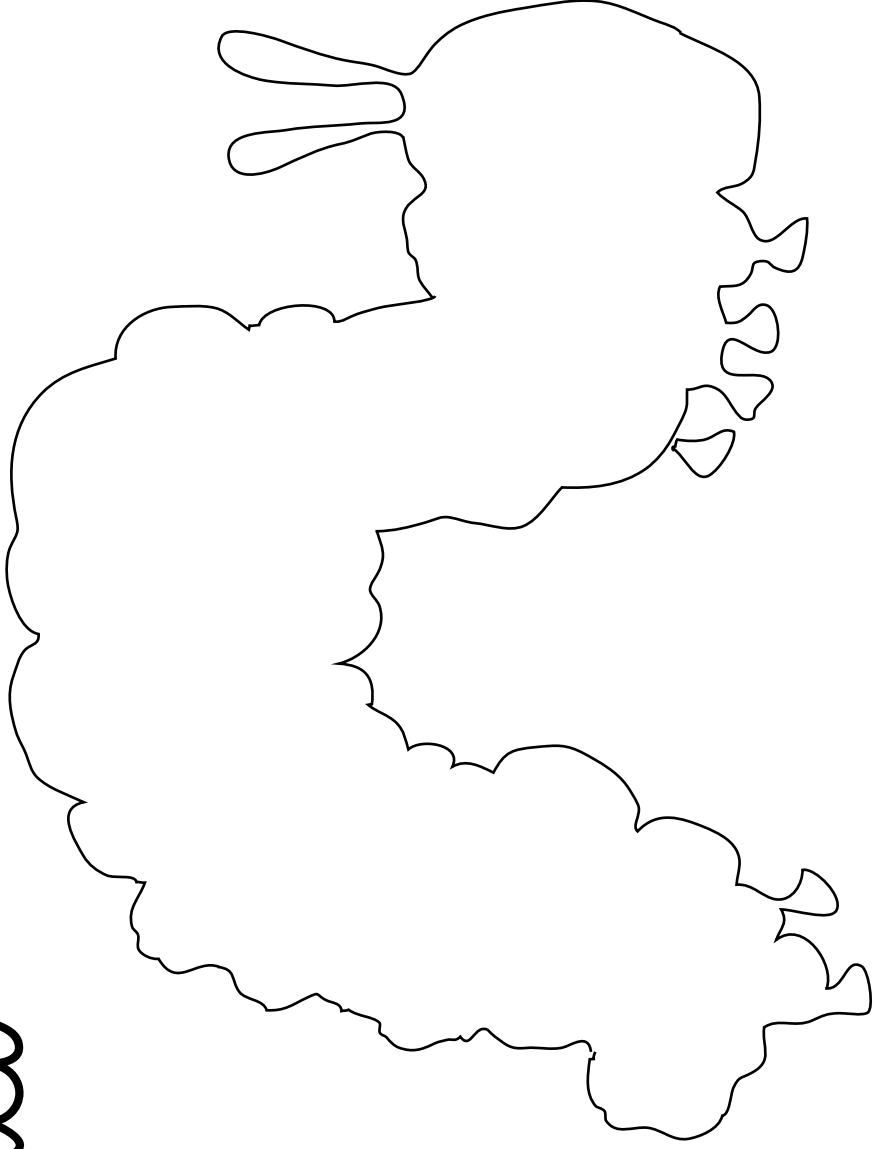

--	--	--	--	--	--	--	--

Lawanija

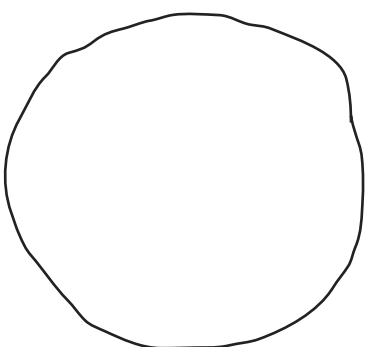

--	--	--	--	--	--

aroma

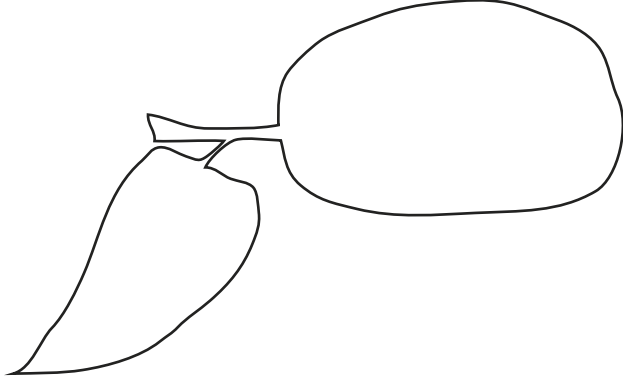

--	--	--	--	--

bağcıma

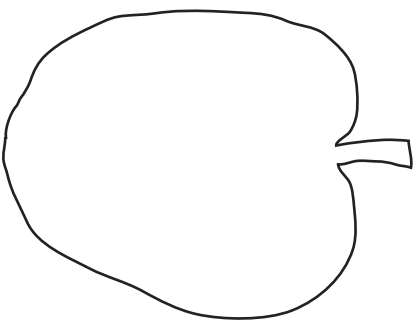

--	--	--	--	--	--	--

hostea

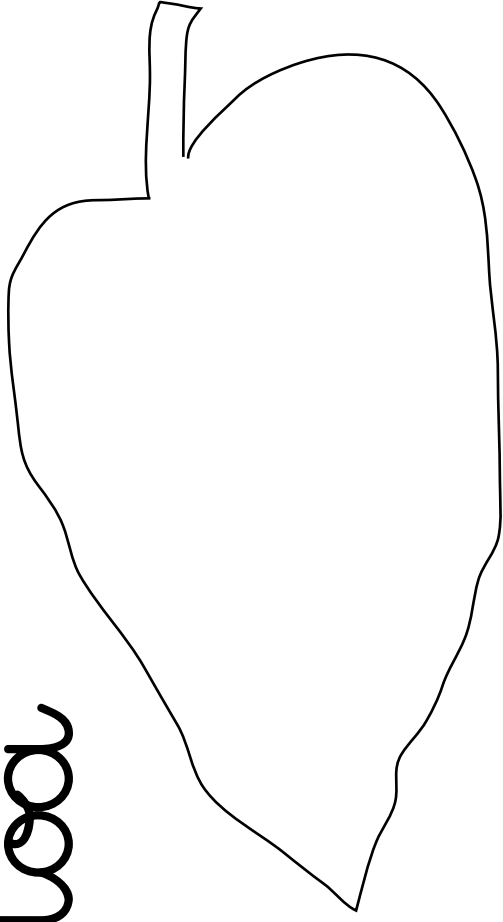

Beldar gosetia

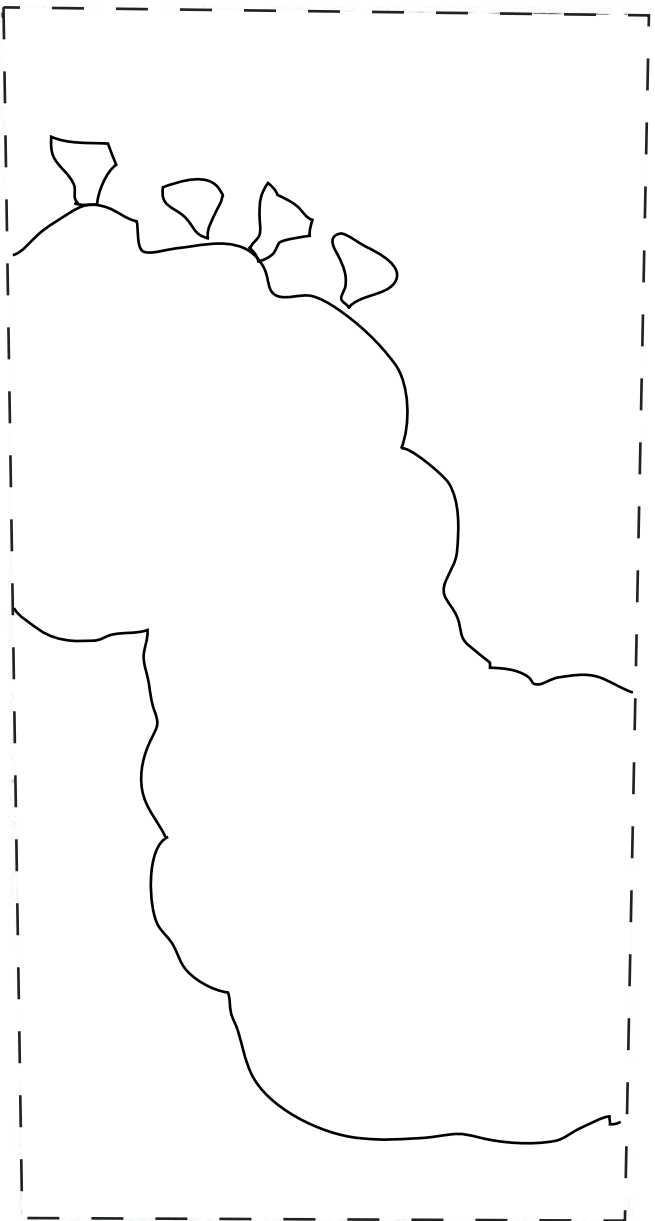
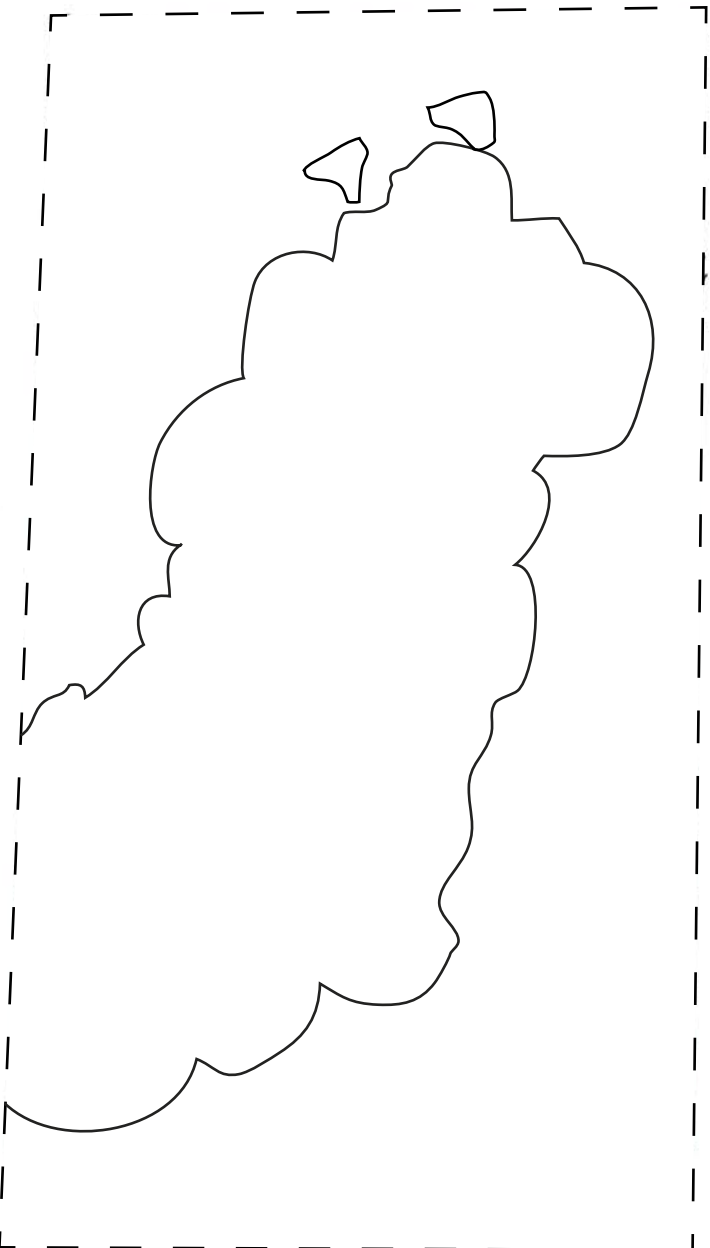
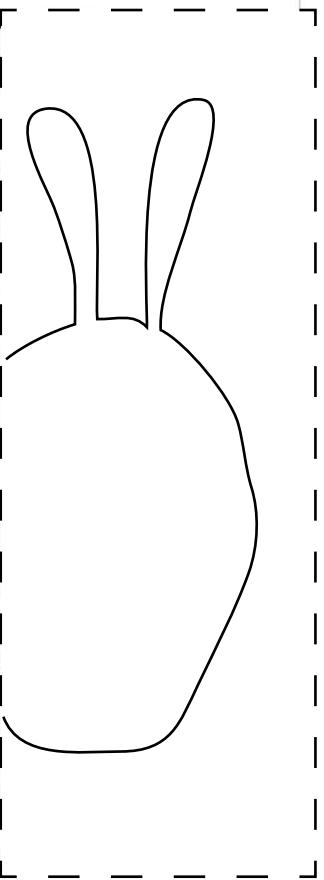

Eric Carle

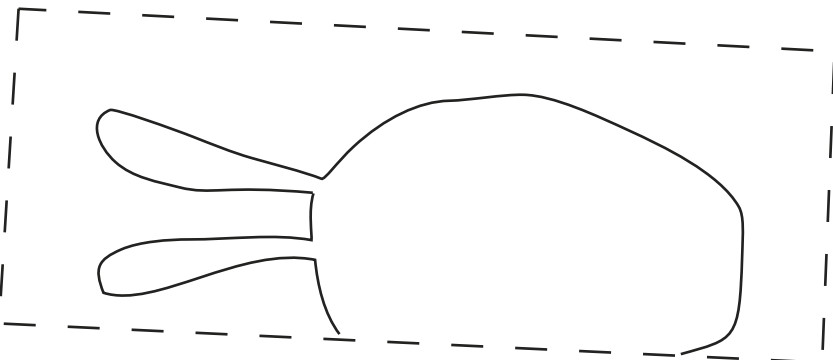
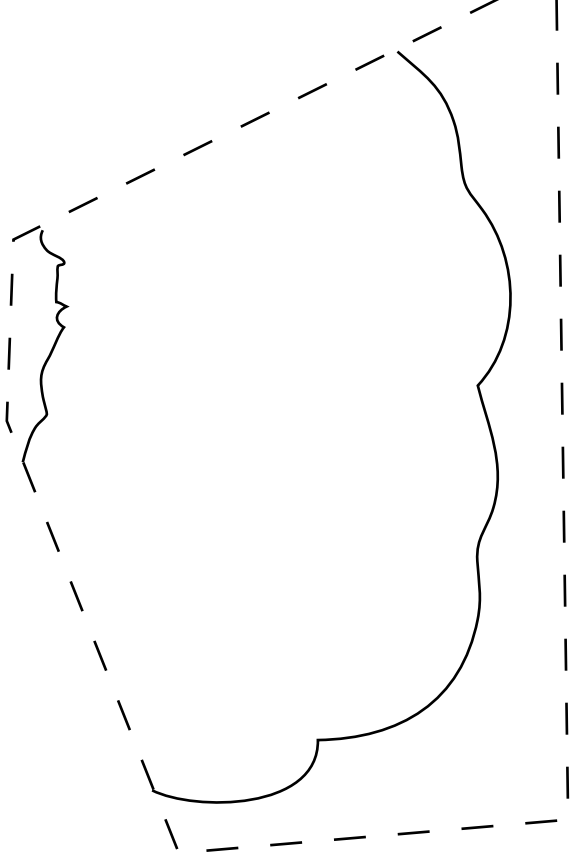
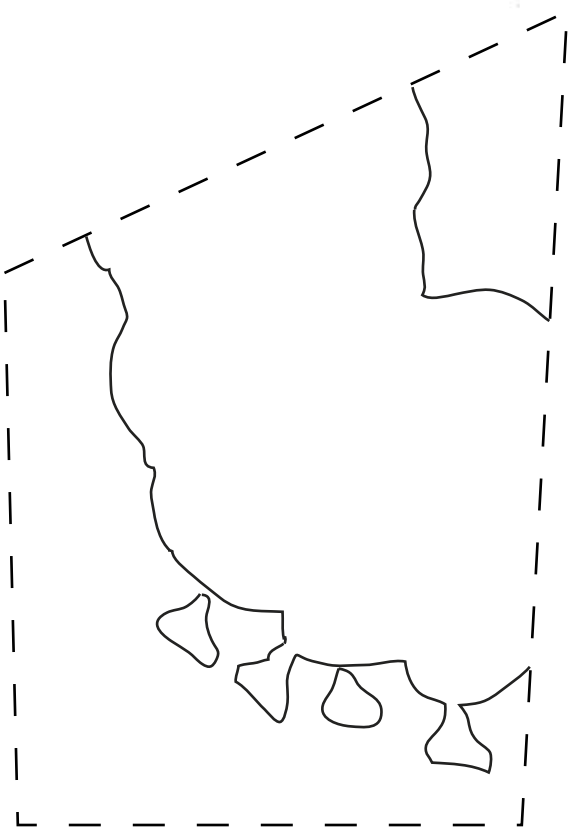

Beldar gosetia

| Eric Carle |

e	a	s	t	a		B	r	g	e	d	o	i
---	---	---	---	---	--	---	---	---	---	---	---	---

e	a	s	t	a		B	r	g	e	d	o	i
---	---	---	---	---	--	---	---	---	---	---	---	---

e	a	s	t	a		B	r	g	e	d	o	i
---	---	---	---	---	--	---	---	---	---	---	---	---

e	a	s	t	a		B	r	g	e	d	o	i
---	---	---	---	---	--	---	---	---	---	---	---	---

e	a	s	t	a		B	r	g	e	d	o	i
---	---	---	---	---	--	---	---	---	---	---	---	---

e	a	s	t	a		B	r	g	e	d	o	i
---	---	---	---	---	--	---	---	---	---	---	---	---

e	a	s	t	a		B	r	g	e	d	o	i
---	---	---	---	---	--	---	---	---	---	---	---	---

e	a	s	t	a		B	r	g	e	d	o	i
---	---	---	---	---	--	---	---	---	---	---	---	---

e	a	s	t	a		B	r	g	e	d	o	i
---	---	---	---	---	--	---	---	---	---	---	---	---

e	a	s	t	a		B	r	g	e	d	o	i
---	---	---	---	---	--	---	---	---	---	---	---	---

e	a	s	t	a	l	B	r	g	e	d	o	i
---	---	---	---	---	---	---	---	---	---	---	---	---

e	a	s	t	a	l	B	r	g	e	d	o	i
---	---	---	---	---	---	---	---	---	---	---	---	---

e	a	s	t	a	l	B	r	g	e	d	o	i
---	---	---	---	---	---	---	---	---	---	---	---	---

e	a	s	t	a	l	B	r	g	e	d	o	i
---	---	---	---	---	---	---	---	---	---	---	---	---

e	a	s	t	a	l	B	r	g	e	d	o	i
---	---	---	---	---	---	---	---	---	---	---	---	---

e	a	s	t	a	l	B	r	g	e	d	o	i
---	---	---	---	---	---	---	---	---	---	---	---	---

e	a	s	t	a	l	B	r	g	e	d	o	i
---	---	---	---	---	---	---	---	---	---	---	---	---

e	a	s	t	a	l	B	r	g	e	d	o	i
---	---	---	---	---	---	---	---	---	---	---	---	---

e	a	s	t	a	l	B	r	g	e	d	o	i
---	---	---	---	---	---	---	---	---	---	---	---	---

e	a	s	t	a	l	B	r	g	e	d	o	i
---	---	---	---	---	---	---	---	---	---	---	---	---

Letrak ordenan ezarriz izenburua osa eta beldarra marraz ezazu.

--	--	--	--	--	--

--	--	--	--	--	--	--

Letrak ordenan ezarriz izenburua osa eta beldarra marraz ezazu.

--	--	--	--	--	--

--	--	--	--	--	--	--

I I

l l

F F F F F F F F

P P P P P P P P

R R R R R R R R

B B B B

D D D D

B F L D A R R A

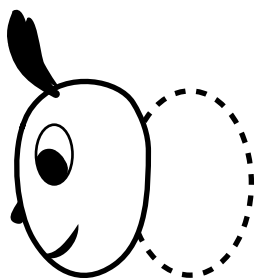

l 0 0

e-

be be be

a-

r-

d-

rr-

beldarra -

beldarra -

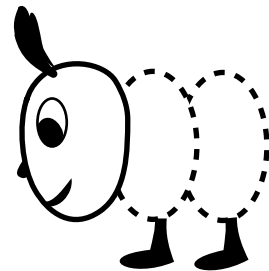

C C C C C C C C C C

S S S S S S S S S S

S S S S S S S S S S

O O O O O O O O O O

G G G G G G G G G G

SAGARRA

SAGARRA

I I

F F F F F F F F

K K K K K K K K

K K K K K K K K

U U U U U U U U

Z Z Z Z Z Z Z Z

G G G G G G G G

F G U Z K A

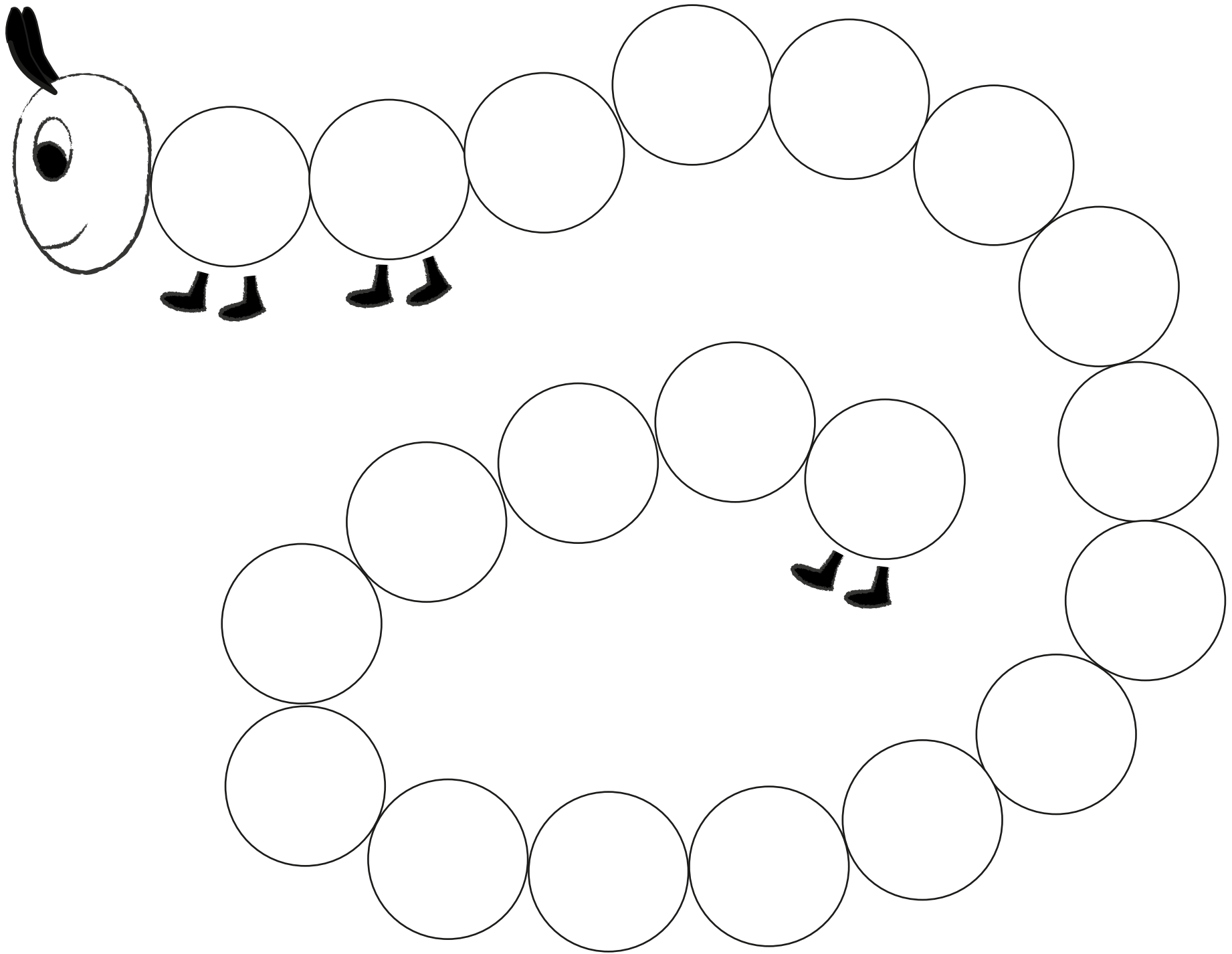

Beldar gosetia : hiztegia

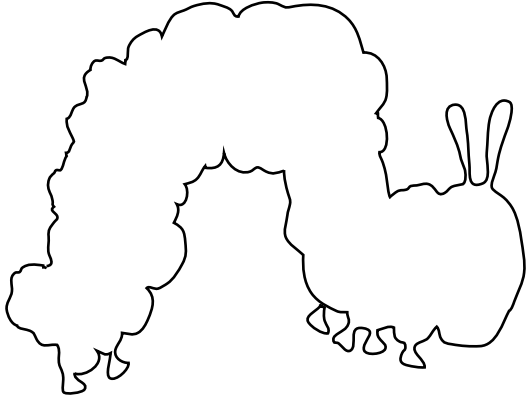

beldarra

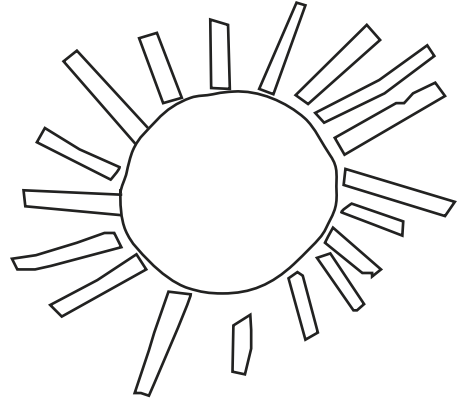

eguzkia

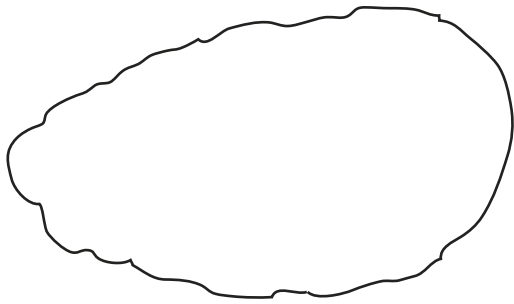

kuskua

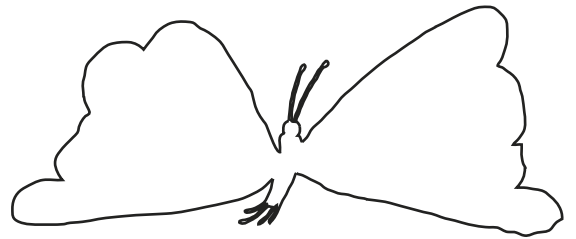

pinpirina

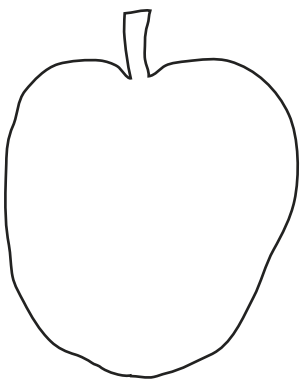

sagarra

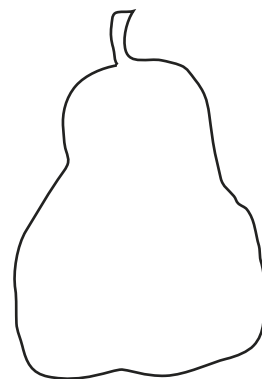

udarea

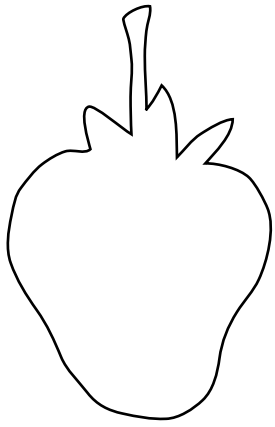

marrubia

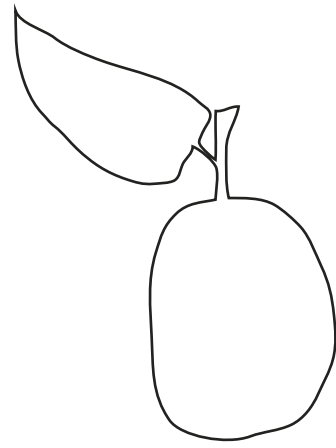

arana

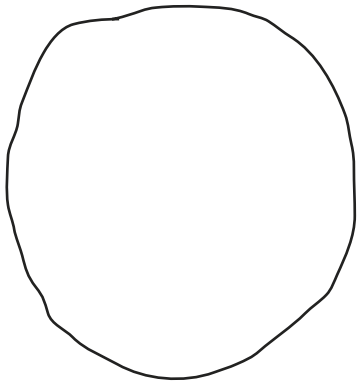

laranja

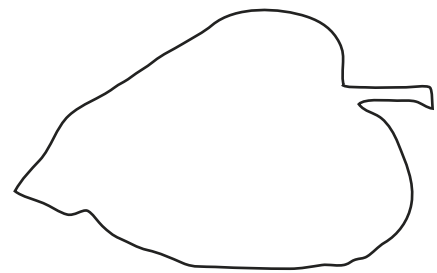

hostoa



ziloa



jan

Beldar gosetia : hiztegia

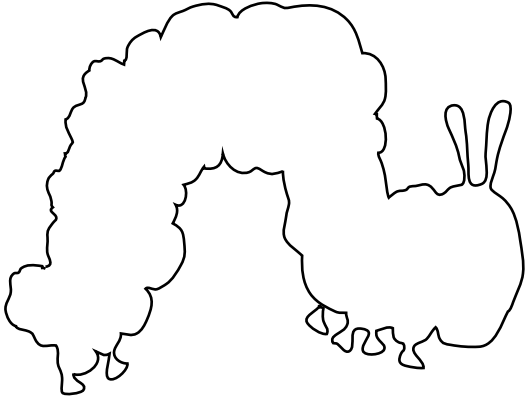

beldarra

beldarra

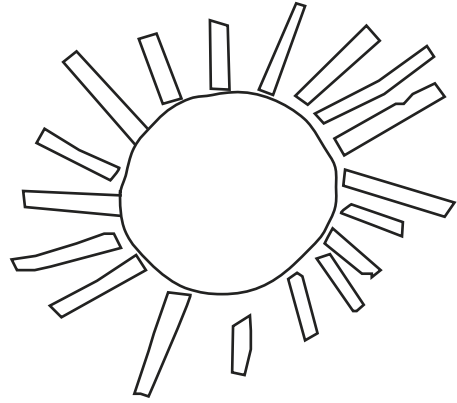

eguzkia

eguzkia

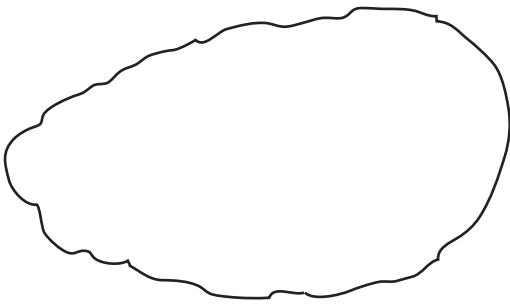

kuskua

kuskua

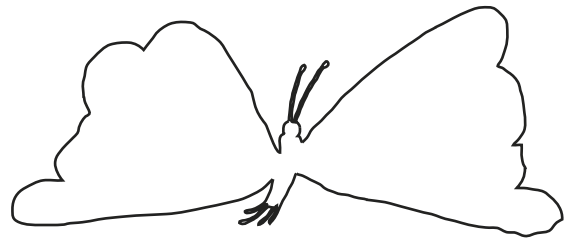

pinpirina

pinpirina

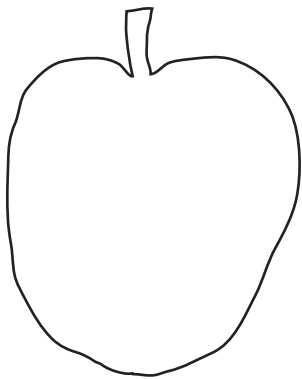

sagarra

sagarra

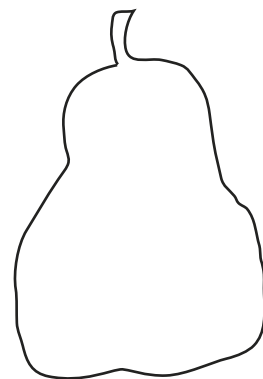

udarea

udarea

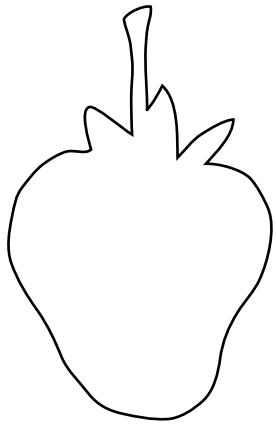

marrubia

marrubia

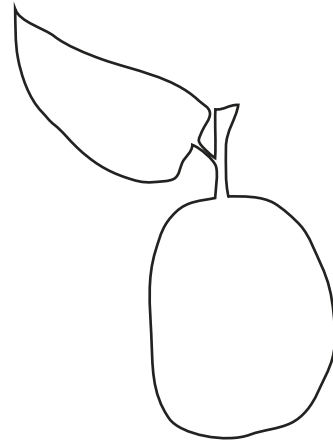

arana

arana

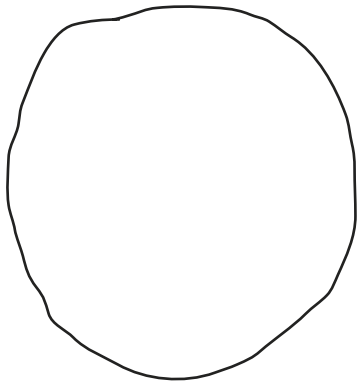

laranja

laranja

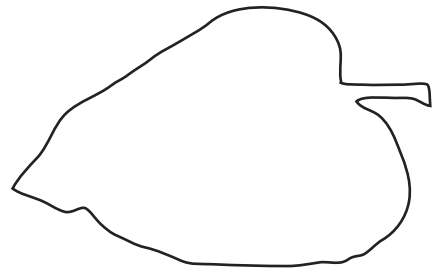

hostoa

hostoa



ziloa

ziloa



jan

jan

arana	beldarra
kuskua	marrubia
hostoa	udarea
pinpirina	sagarra

arana	beldarra
kuskua	marrubia
hostoa	udarea
pinpirina	sagarra

arana	beldarra
kuskua	marrubia
hostoa	udarea
pinpirina	sagarra

arana	beldarra
kuskua	marrubia
hostoa	udarea
pimpirina	sagarra

arana	beldarra
kuskua	marrubia
hostoa	udarea
pimpirina	sagarra

arana	beldarra
kuskua	marrubia
hostoa	udarea
pimpirina	sagarra

Irudien izenak atzeman eta kola itzazu.

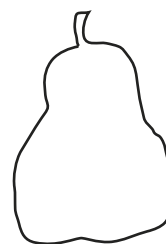
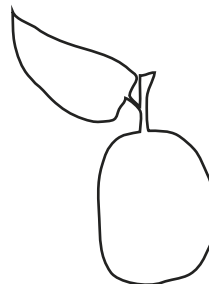
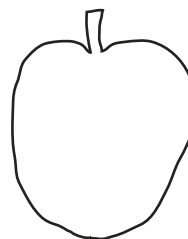
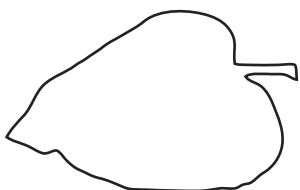
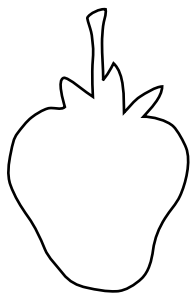

k	u	s	k	u	a	h	o	s
t	o	a	u	r	m	e	l	o
i	a	l	a	r	a	n	j	a
m	a	r	r	u	b	i	a	a
r	a	n	a	s	a	g	a	r
r	a	u	d	a	r	e	a	p
i	n	p	i	r	i	n	a	b
e	l	d	a	r	r	a		

udarea

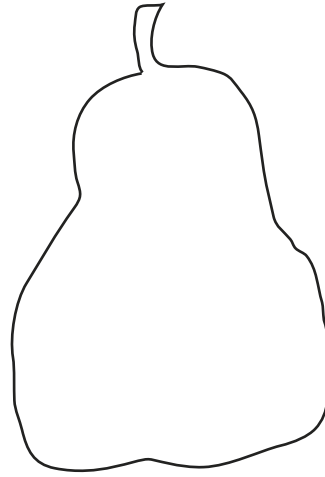

--	--	--	--	--	--

pinpirina

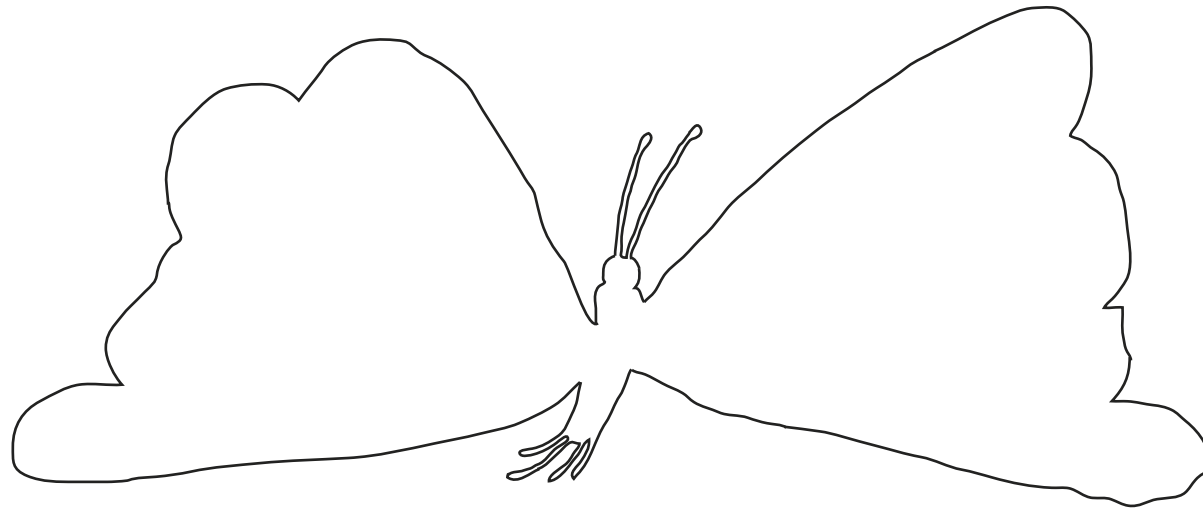

--	--	--	--	--	--	--	--	--

arana

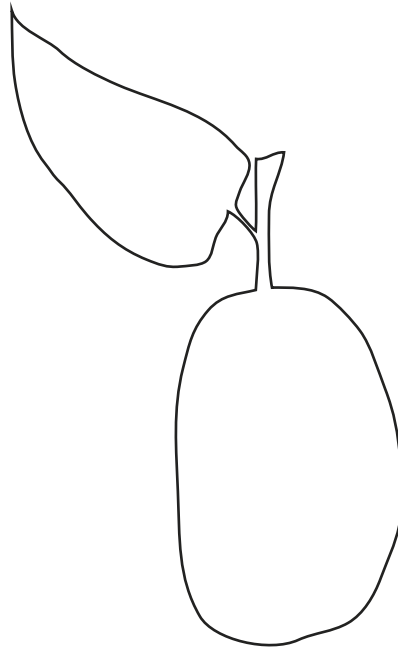

--	--	--	--	--

marrubia

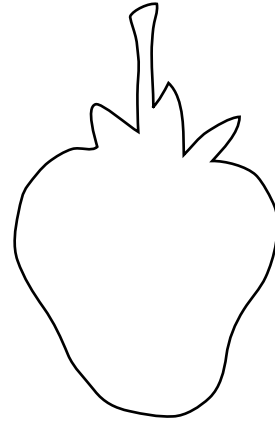

--	--	--	--	--	--	--	--

beldarra

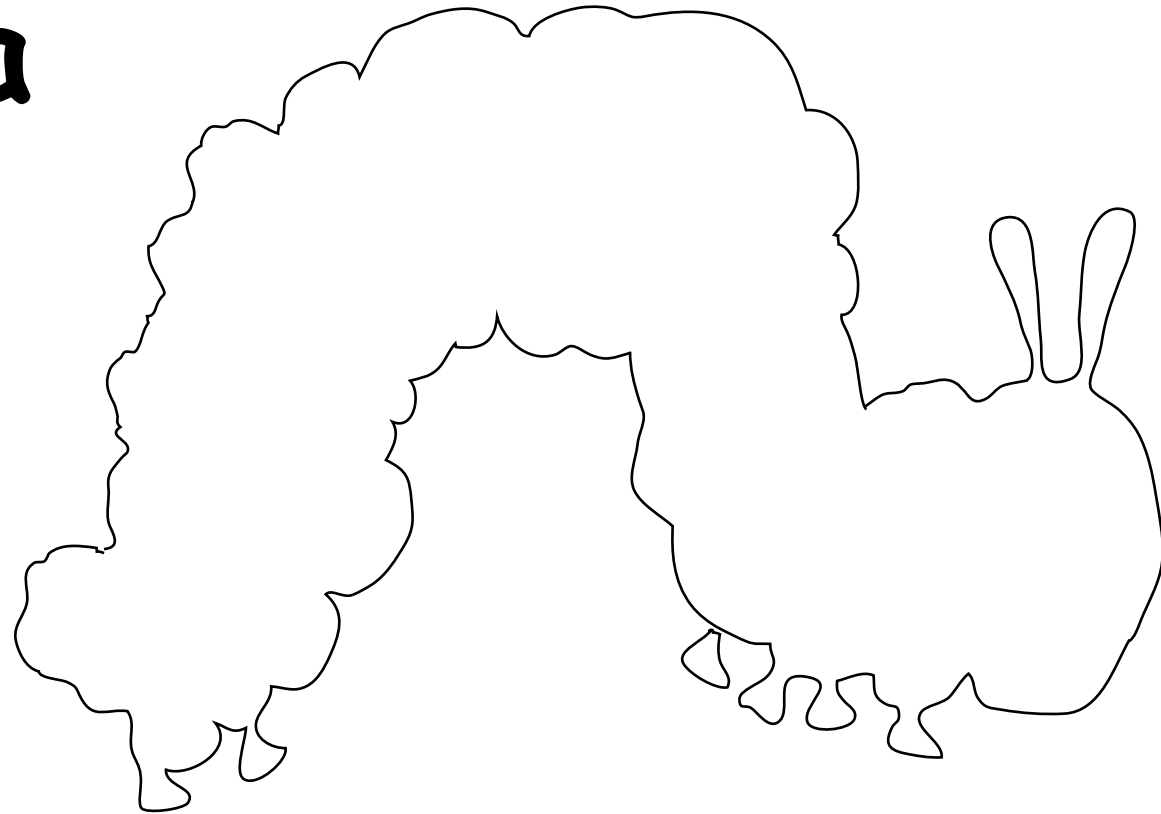

--	--	--	--	--	--	--	--

ur-meloia

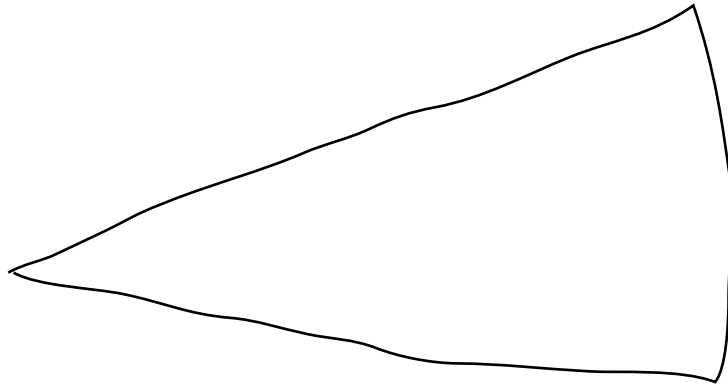

--	--

--	--	--	--	--	--

laranja

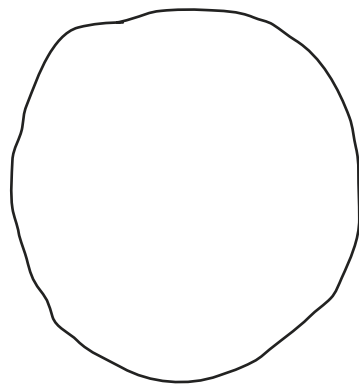

--	--	--	--	--	--	--

kuskua

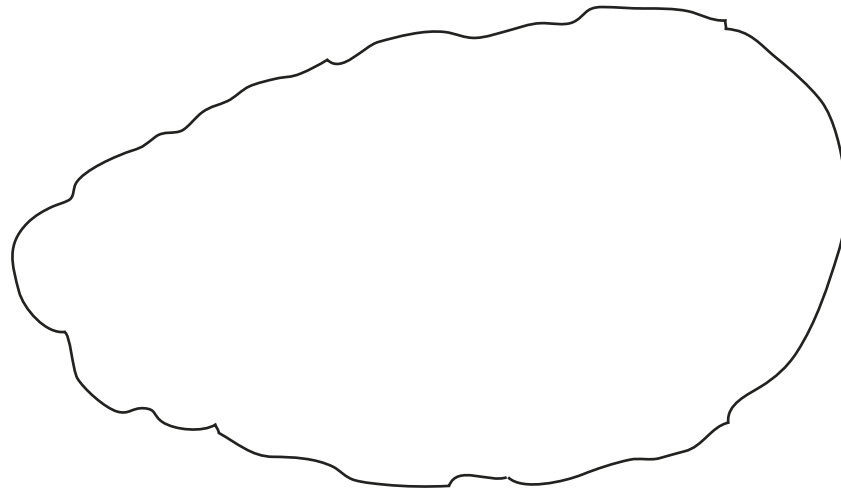

--	--	--	--	--	--

hostoa

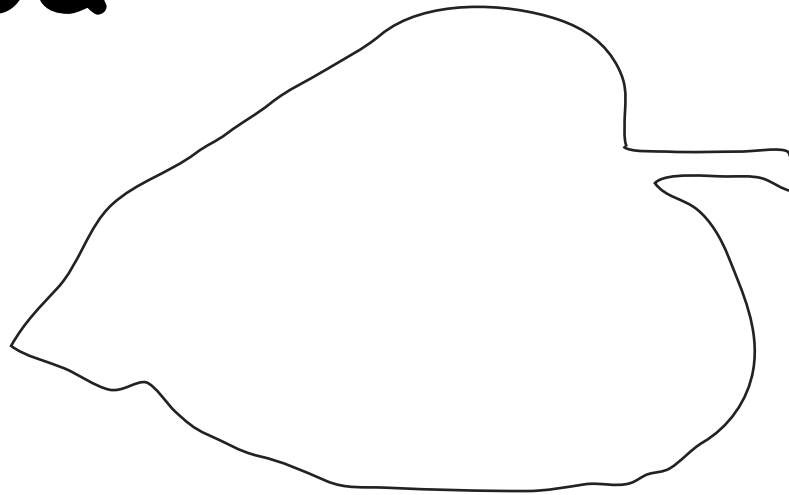

--	--	--	--	--	--

sagarra

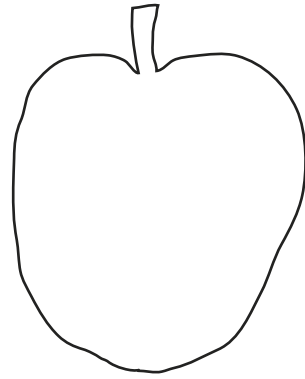

--	--	--	--	--	--	--

Irudien izenak idatz itzazu.

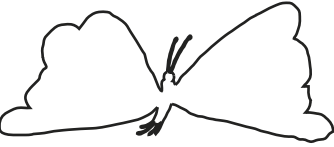
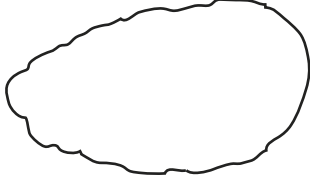
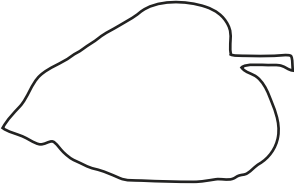
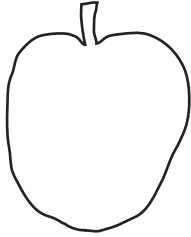
	<hr/> <hr/>
	<hr/> <hr/>
	<hr/> <hr/>
	<hr/> <hr/>
	<hr/> <hr/>

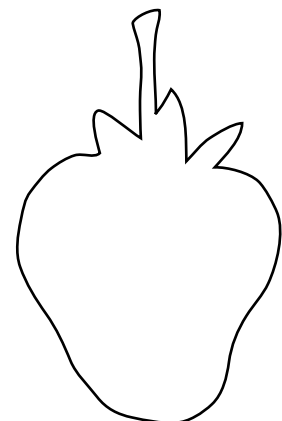
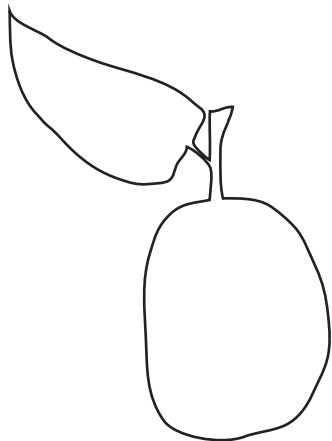
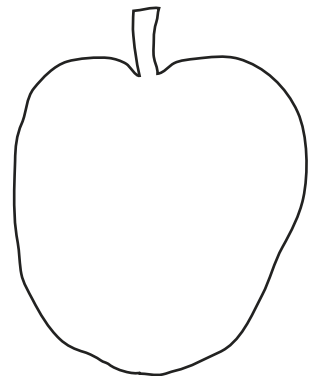
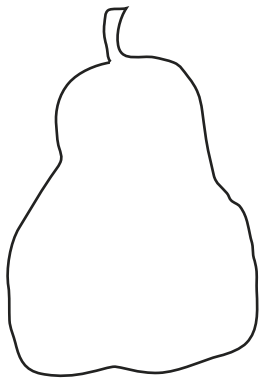
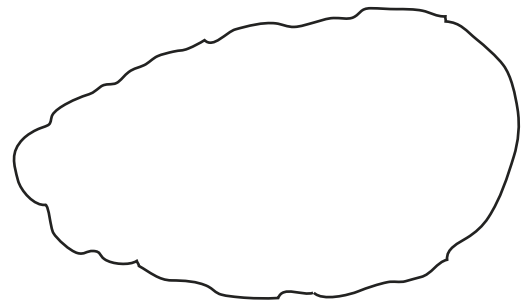
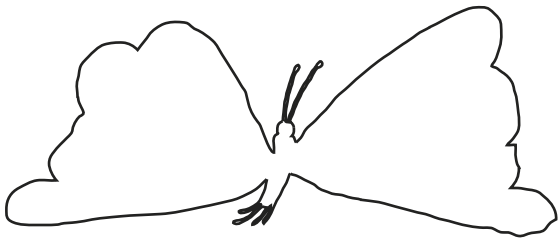
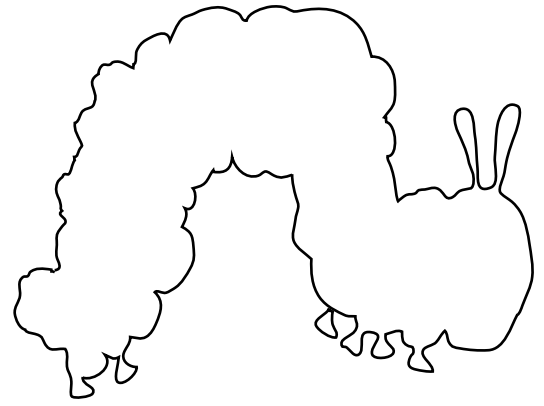
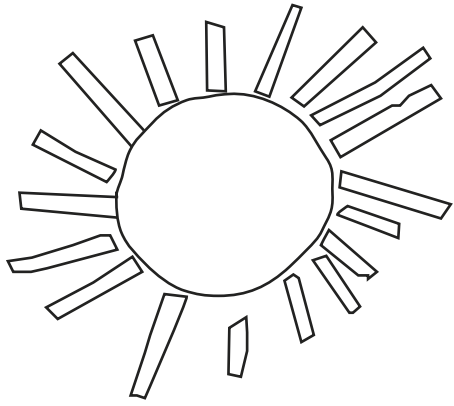

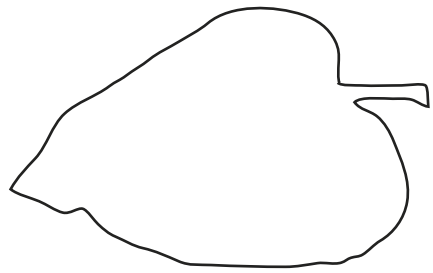
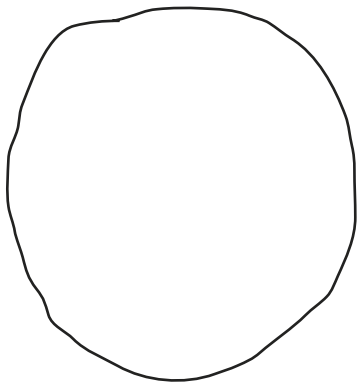
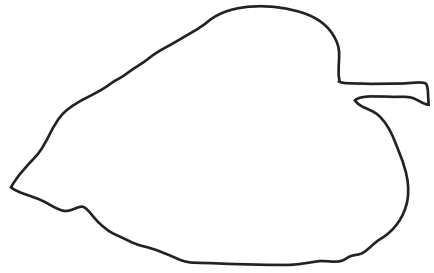
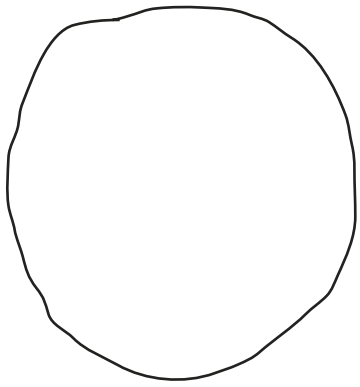

sagarra

arana

marrubia

udarea

laranja

hostoa

kuskua

eguzkia

beldarra

pinpirina

sagarra

arama

marrubia

udarea

laranja

hostoa

kuskua

eguzkia

beldarra

pimpinina

Hitzak ordenan ezar itzazu erranaldiaren berriz osatzeko. Ondotik marraz ezazu.

bat	du.	Beldarrak	jan	sagar
-----	-----	-----------	-----	-------

bat	du.	Beldarrak	jan	sagar
-----	-----	-----------	-----	-------

bat	du.	Beldarrak	jan	sagar
-----	-----	-----------	-----	-------

bat	du.	Beldarrak	jan	sagar
-----	-----	-----------	-----	-------

Hitzak ordenan ezar itzazu erranaldiaren osatzeko. Ondotik marraz ezazu.

bi	ditu.	Beldarrak	jan	udare
----	-------	-----------	-----	-------

bi	ditu.	Beldarrak	jan	udare
----	-------	-----------	-----	-------

bi	ditu.	Beldarrak	jan	udare
----	-------	-----------	-----	-------

bi	ditu.	Beldarrak	jan	udare
----	-------	-----------	-----	-------

Hitzak ordenan ezar itzazu erranaldiaren berriz osatzeko. Ondotik marraz ezazu.



hiru	ditu.	Beldarrak	jan	aran
------	-------	-----------	-----	------



hiru	ditu.	Beldarrak	jan	aran
------	-------	-----------	-----	------



hiru	ditu.	Beldarrak	jan	aran
------	-------	-----------	-----	------

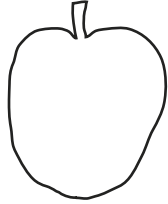

hiru	ditu.	Beldarrak	jan	aran
------	-------	-----------	-----	------

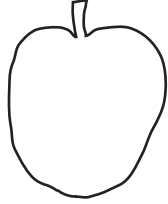

Erranaldia osa ezazu hitzak eta irudiak ordenan ezarriz. Ondotik, marraz ezazu.

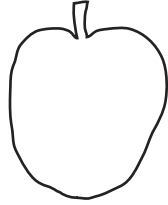
	1			
bat	jan du.	Astelehenean	beldarrak	sagar

	1			
bat	jan du.	Astelehenean	beldarrak	sagar

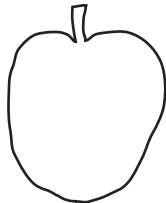
	1			
bat	jan du.	Astelehenean	beldarrak	sagar

	1			
bat	jan du.	Astelehenean	beldarrak	sagar
bat	jan du.	Astelehenean	beldarrak	sagar

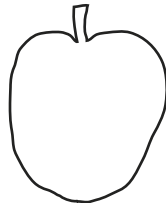
	1			
bat	jan du.	Astelehenean	beldarrak	sagar
bat	jan du.	Astelehenean	beldarrak	sagar

Irakurketa

Erranaldiaren hitzak ordenan ezar itzazu.

jan du.	sagar	Astelehenean	bat	beldarrak
<input type="checkbox"/>	<input type="checkbox"/>	<input type="checkbox"/>	<input type="checkbox"/>	<input type="checkbox"/>

Eskas diren hitzak idatz itzazu.

Astelehenean sagar bat jan du.

Astelehenean beldarrak sagar bat

Astelehenean beldarrak bat jan du.

Astelehenean beldarrak sagar jan du.

Marrak eginez hitzak bereiz itzazu.

Asteleheneanbeldarraksagarbatjandu.

Erranaldi honetan hitz bat soberakin bada. Aurki eta marra ezazu.

Astelehenean harrak sagar gorri bat jan du.

Hitz berak aurki eta ingura itzazu.

Astelehenean	beldarrak	sagar	bat	jan du.
Asteartean	harrak	sagar	bi	jo du.
Asteazkenean	beltxargak	sator	bat	jan ditu.
Astelehenean	belarrak	sagu	be	jan du.
Agorrilgan	beldarrak	sakela	bu	joan da.

beldarrak

sagar



bat

jan



du

Hitzak ordena itzazu erranaldiaren berriz egiteko eta marrazkia egizu.

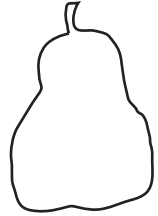
Asteartean

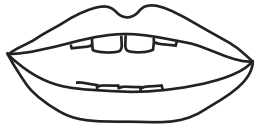
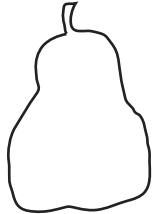

	2			
jan ditu.	bi	udare	beldarrak	Asteartean

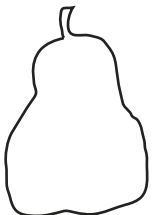

	2			
jan ditu.	bi	udare	beldarrak	Asteartean

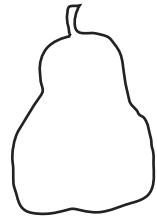

	2			
jan ditu.	bi	udare	beldarrak	Asteartean

Hitzak ordenan ezar erramaldiaren berrosatzeko. Ondotik marraz ezazu.

Asteartean

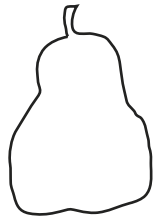
	2			
jan ditu.	bi	udare	beldarrak	Asteartean

	2			
jan ditu.	bi	udare	beldarrak	Asteartean

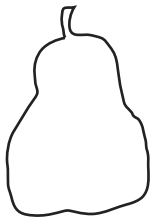
	2			
jan ditu.	bi	udare	beldarrak	Asteartean

Erranaldiaren hitzak ordena zenbakien segida idatziz.

bi	jan ditu.	Asteartean	udare	beldarrak
<input type="checkbox"/>	<input type="checkbox"/>	<input type="checkbox"/>	<input type="checkbox"/>	<input type="checkbox"/>

Hitz berak atzeman eta ingura itzazu :

Asteartean	beldarrak	bi	udare	jan ditu
Asteazkenean	bizarrak	bat	uhain	jan ditu
Astelehenean	bakarrak	bi	uztai	jakin du
Asteartean	elurrak	hiru	udare	jin dira
Asteazkenean	beldarrak	bost	uharte	Jo ditu

Hitzak motz marrak eginez.

Astearteanbeldarrakbiudarejanditu.

Asteartean

Asteartean

Asteartean

Asteartean

Hitz bera atzemazu.

beldarra

beltza belarra

beldarra belea

beltxarga beldarra

beldarra behatza

Eskas diren hizkiak idatz itzazu.

BELDARRA

BELD...RRA

...E.....A...RA

B.....R.....

.....

Hitz bera atzemazu.

beldarra

behia belarra

belarria begia

beldarra belea

beldarra besoa

beltxarga beldarra

beldarra behatza

Eskas diren hizkiak idatz itzazu.

beldarra

beld...rra

be...da...ra

...e.....a...ra

b.....r.....

.....a.....a

.....

Astelehenean	Asteartean	Asteazkenean
Ostegunean	Ostiralean	Larunbatean

Astelehenean	Asteartean	Asteazkenean
Ostegunean	Ostiralean	Larumbatean

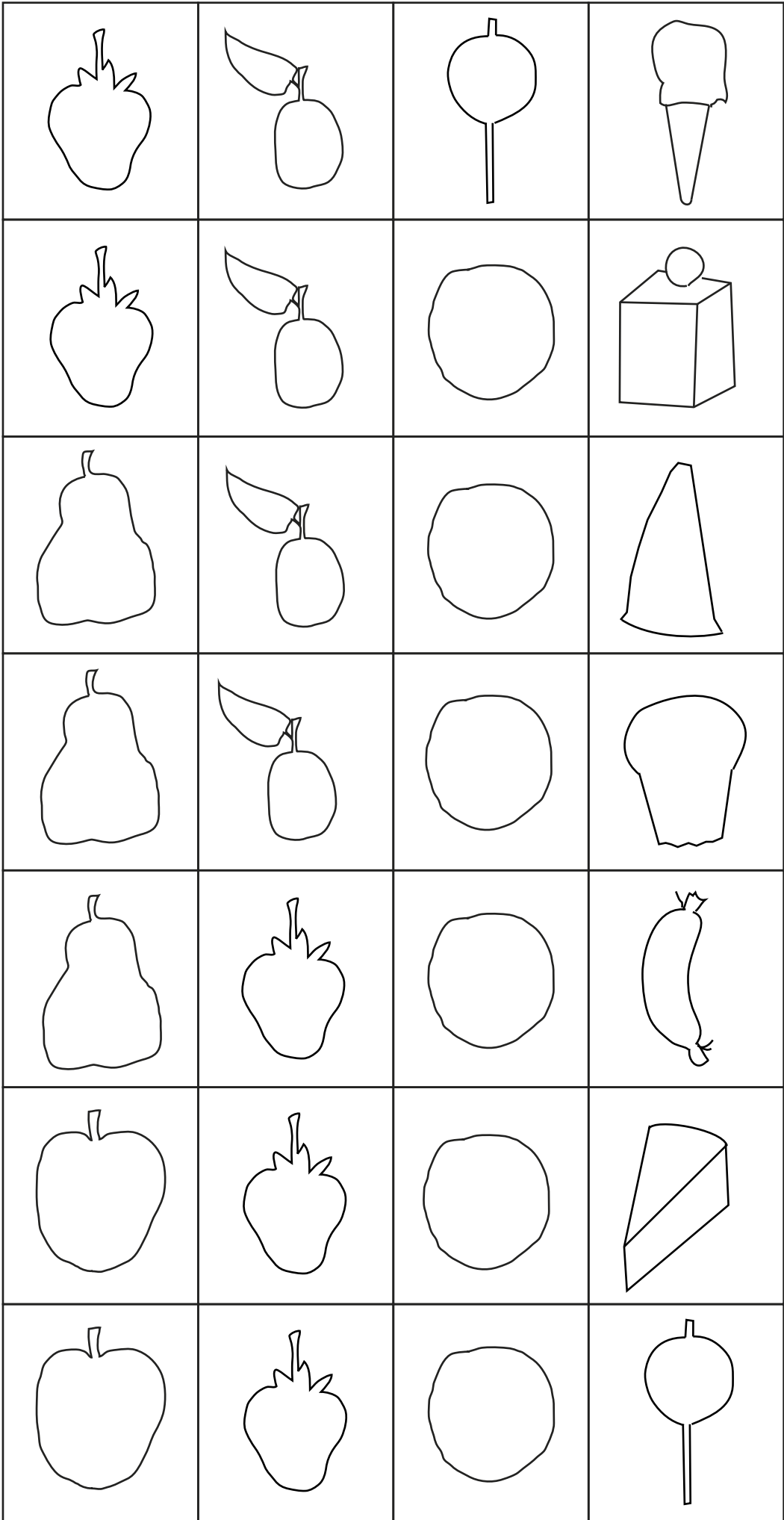

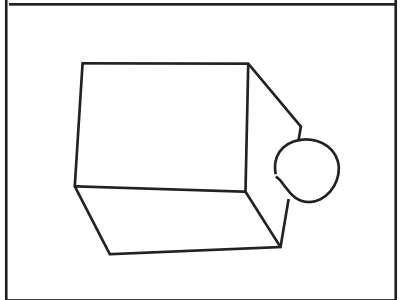
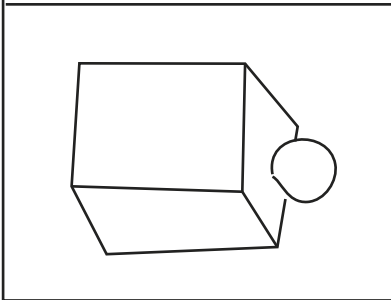
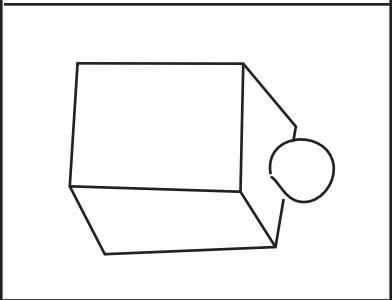
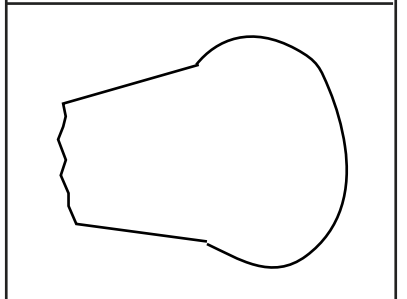
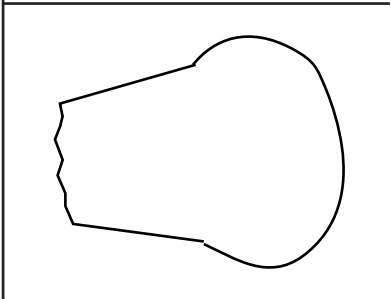
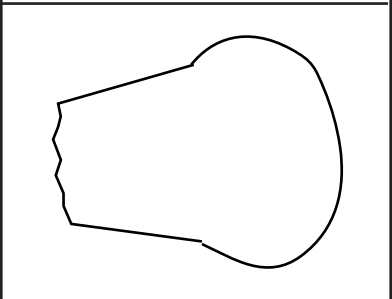
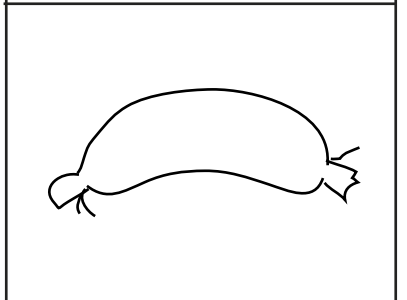
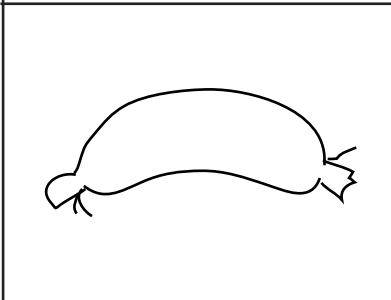
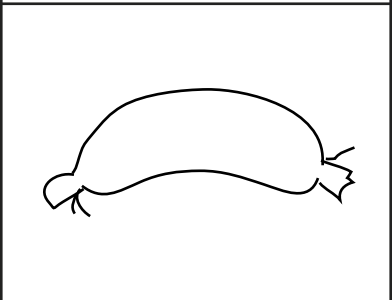
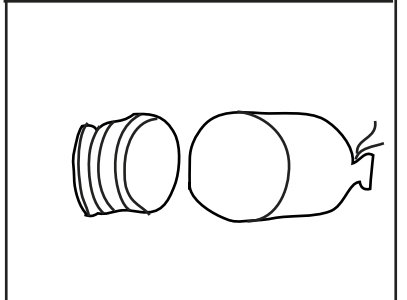
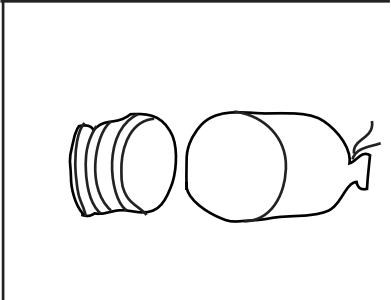
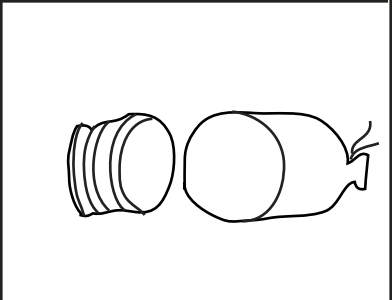
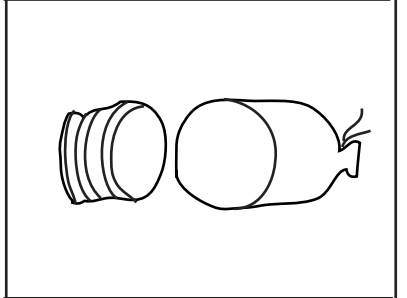
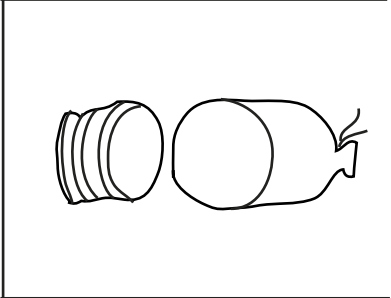
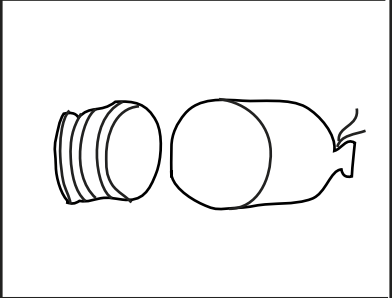
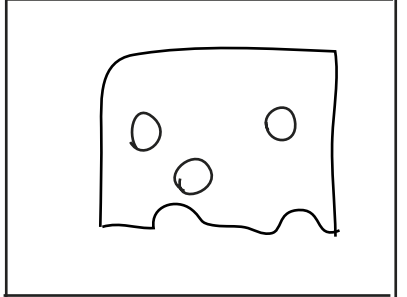
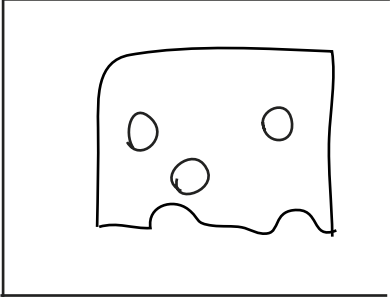
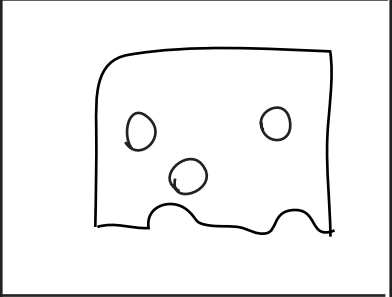
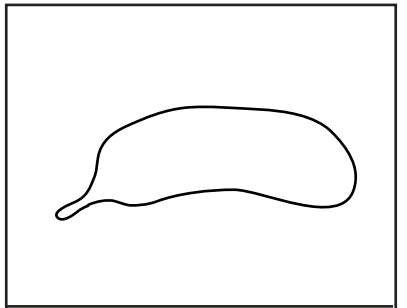
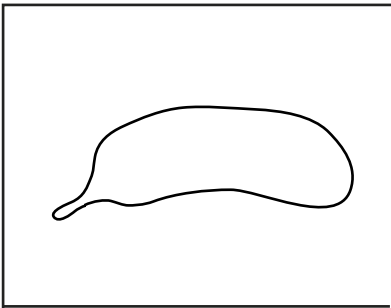
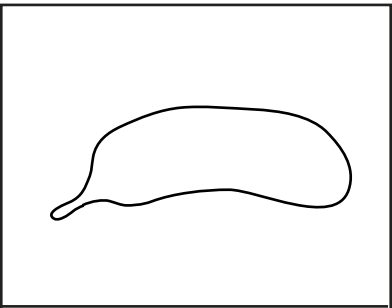

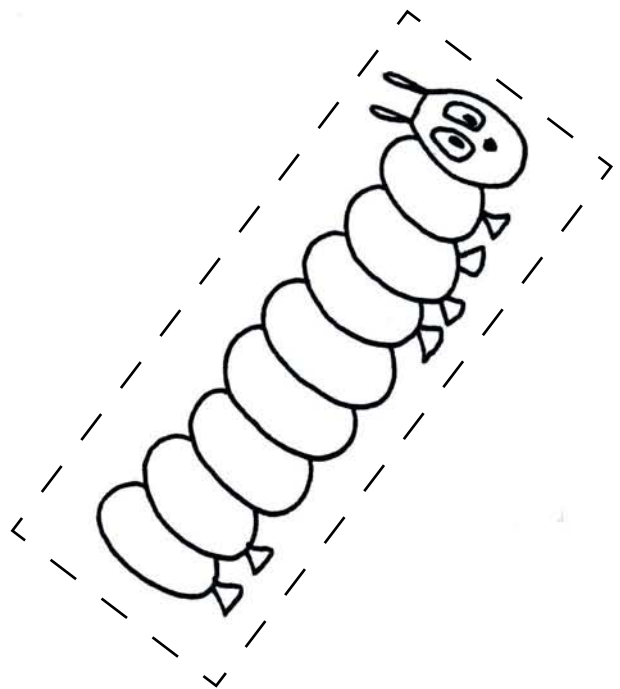
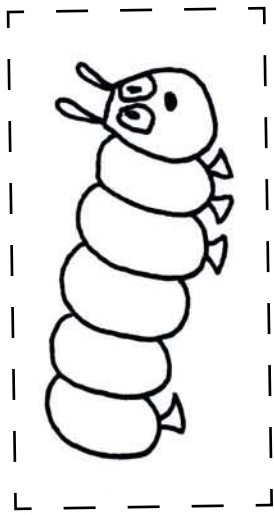
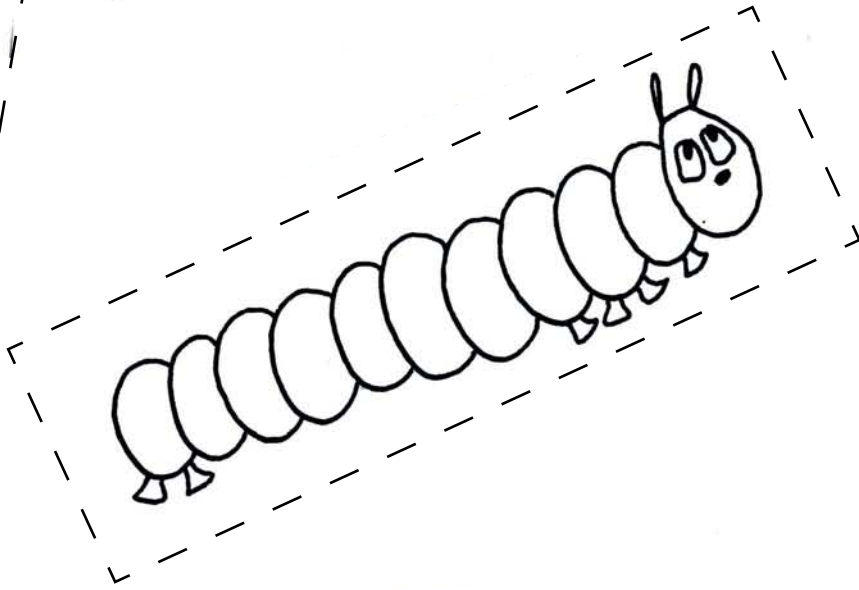
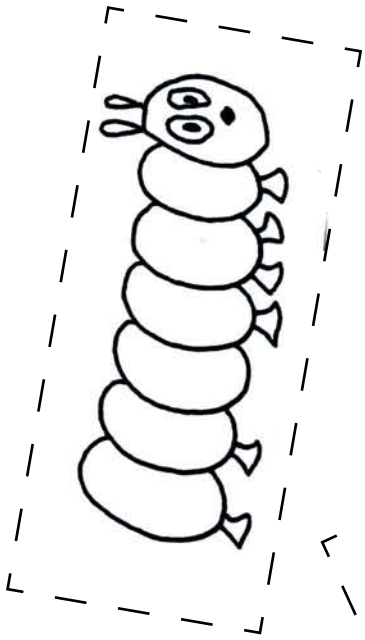
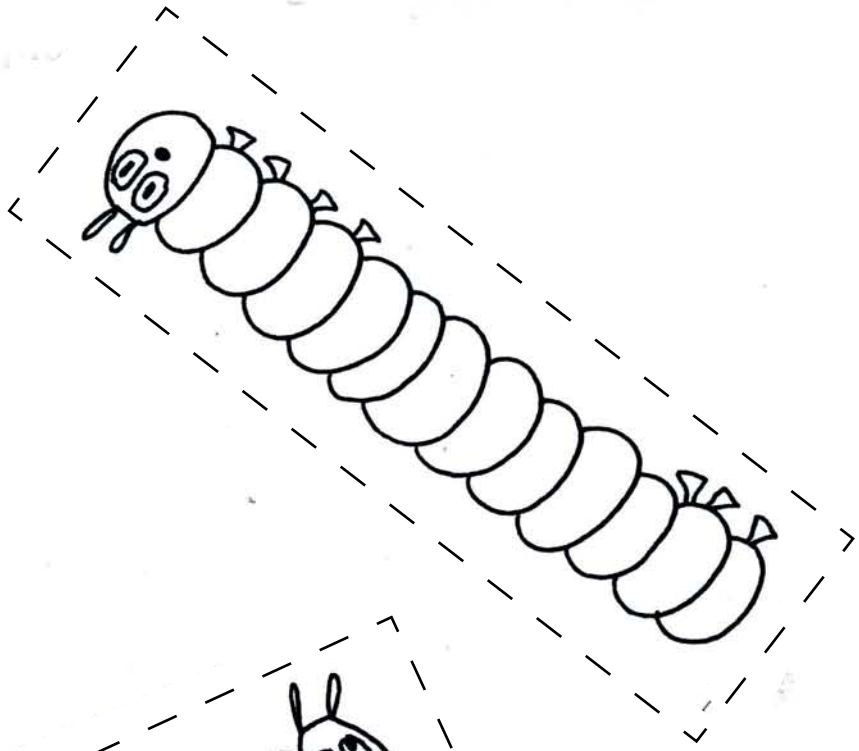

Beldarrak motz itzazu eta laburrenetik luzeenera sailka.

A diagram consisting of six horizontal bars stacked vertically. Each bar is longer than the one above it, creating a staircase effect. The bars are empty and intended for labeling.

Fritu multzoak zenbatu eta, zenbakiak kola itzazu.

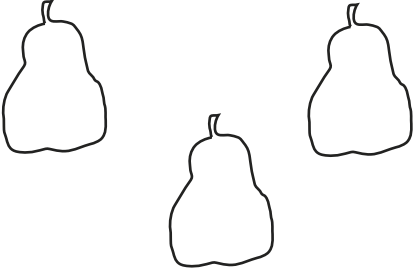

Three pears are arranged in a triangular pattern: one at the top left, one at the top right, and one in the center below them. Below the pears is a square box for counting.

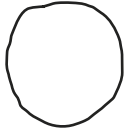

A single orange is centered at the top. Below it is a square box for counting.

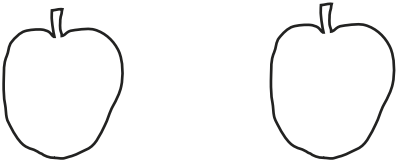

Two apples are arranged horizontally. Below them is a square box for counting.

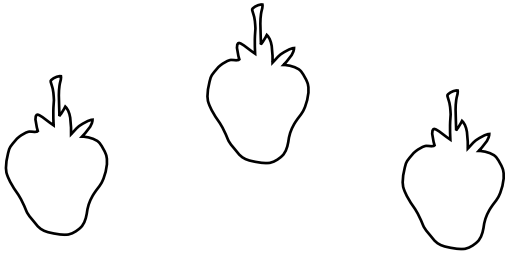

Three strawberries are arranged horizontally. Below them is a square box for counting.

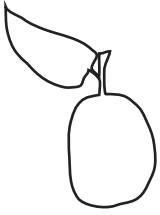

A single kiwi fruit with a stem and two leaves is centered. Below it is a square box for counting.



Two lemons are arranged horizontally. Below them is a square box for counting.



Two oranges are arranged horizontally. Below them is a square box for counting.

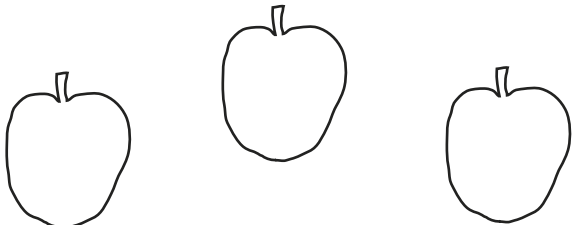

Three apples are arranged horizontally. Below them is a square box for counting.

3	2	1	3	2	1	3	2
---	---	---	---	---	---	---	---

3	2	1	3	2	1	3	2
---	---	---	---	---	---	---	---

3	2	1	3	2	1	3	2
---	---	---	---	---	---	---	---

3	2	1	3	2	1	3	2
---	---	---	---	---	---	---	---

3	2	1	3	2	1	3	2
---	---	---	---	---	---	---	---

3	2	1	3	2	1	3	2
---	---	---	---	---	---	---	---

3	2	1	3	2	1	3	2
---	---	---	---	---	---	---	---

3	2	1	3	2	1	3	2
---	---	---	---	---	---	---	---

3	2	1	3	2	1	3	2
---	---	---	---	---	---	---	---

3	2	1	3	2	1	3	2
---	---	---	---	---	---	---	---

3 kolore hauta eta beldarra margo ezazu, koloreak aldizkatuz.

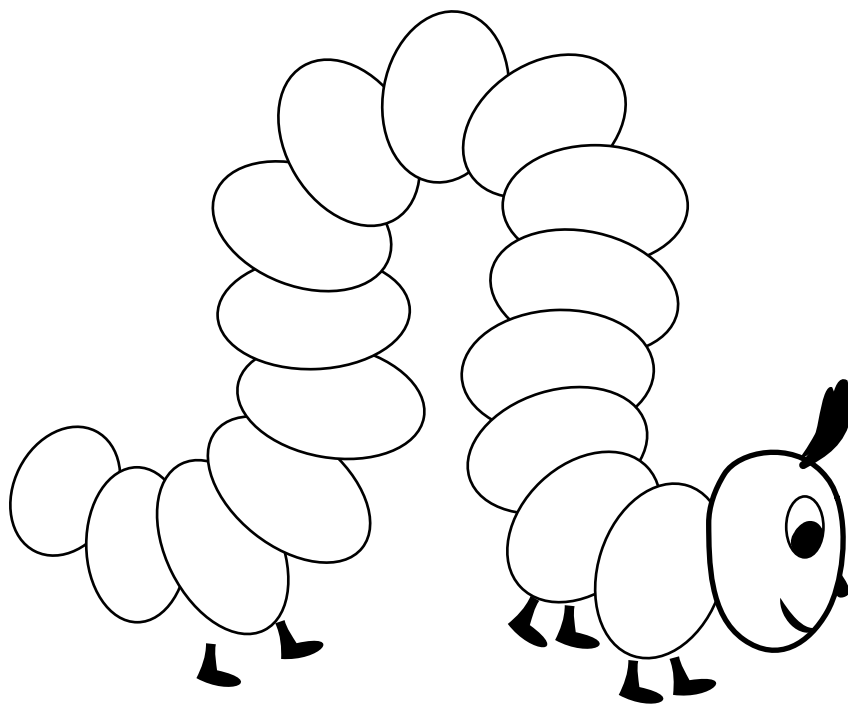

3 kolore hauta eta beldarra margo ezazu, koloreak aldizkatuz.

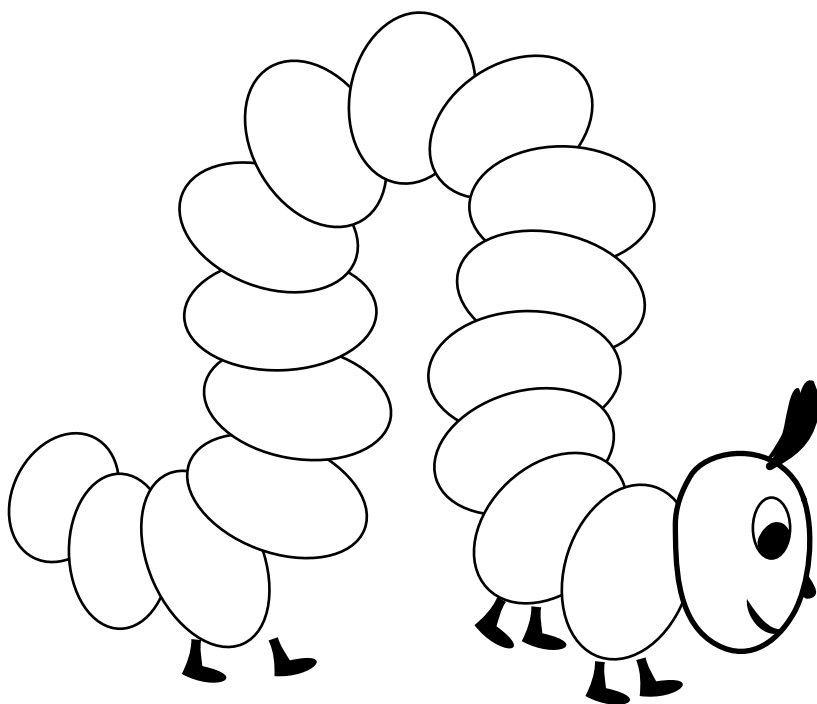

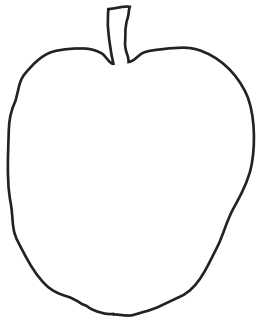

sagar

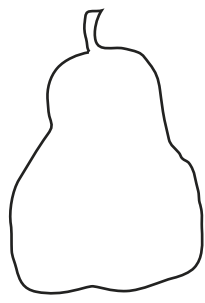

udare

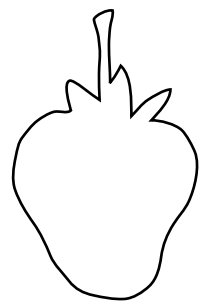

marrubi

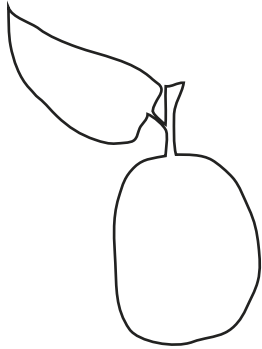

aran

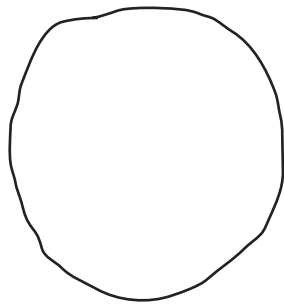

laranja

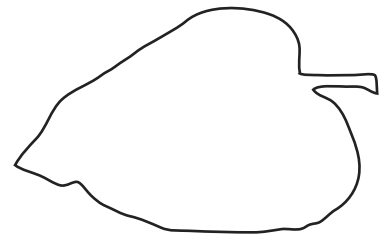

hosto

1

bat

2

bi

3

hiru

4

lau

5

bost

6

sei

Galdegin fruitu kopurua kola ezazu.

hiru marrubi

laranja bat

bost sagar

bi udare

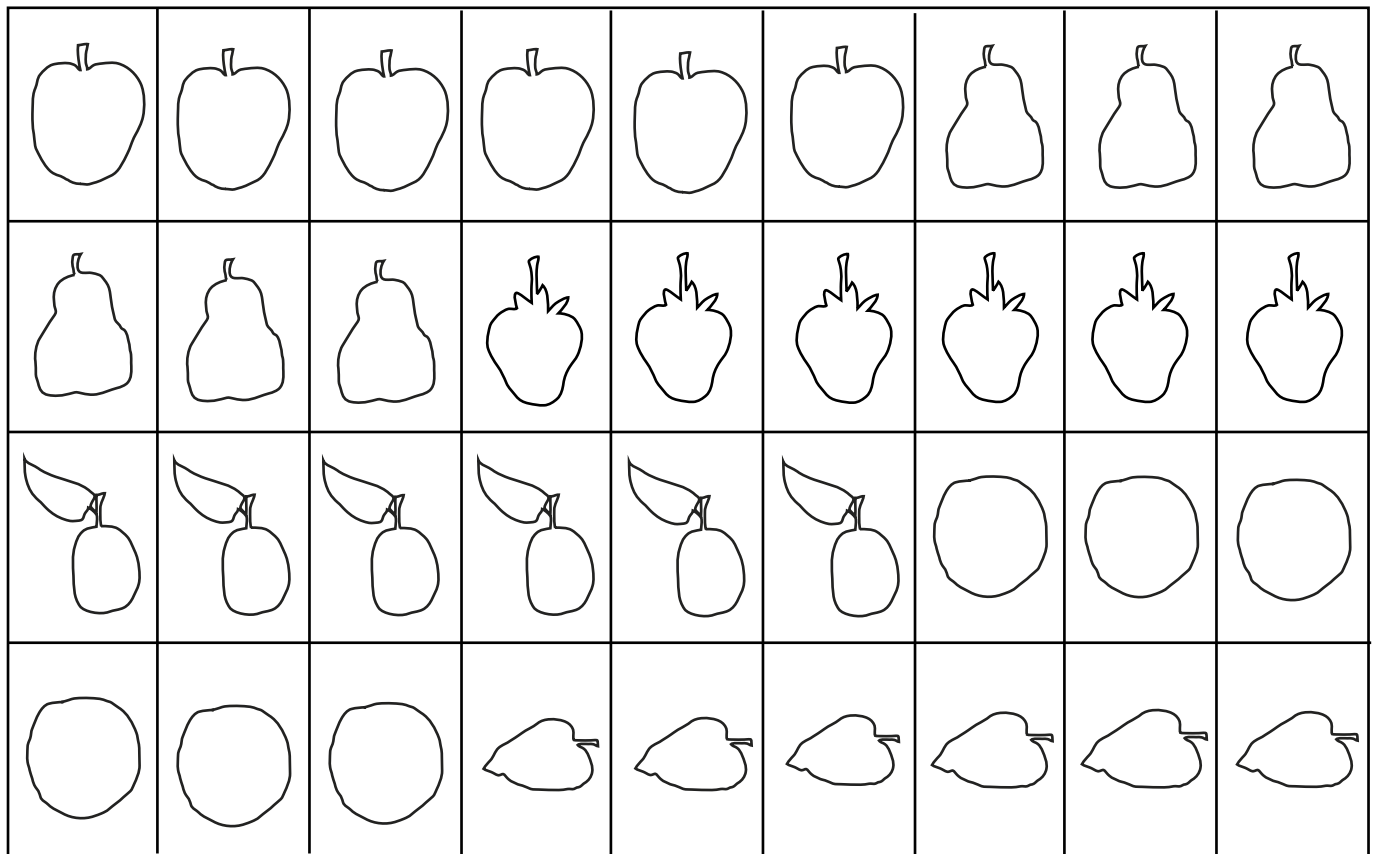
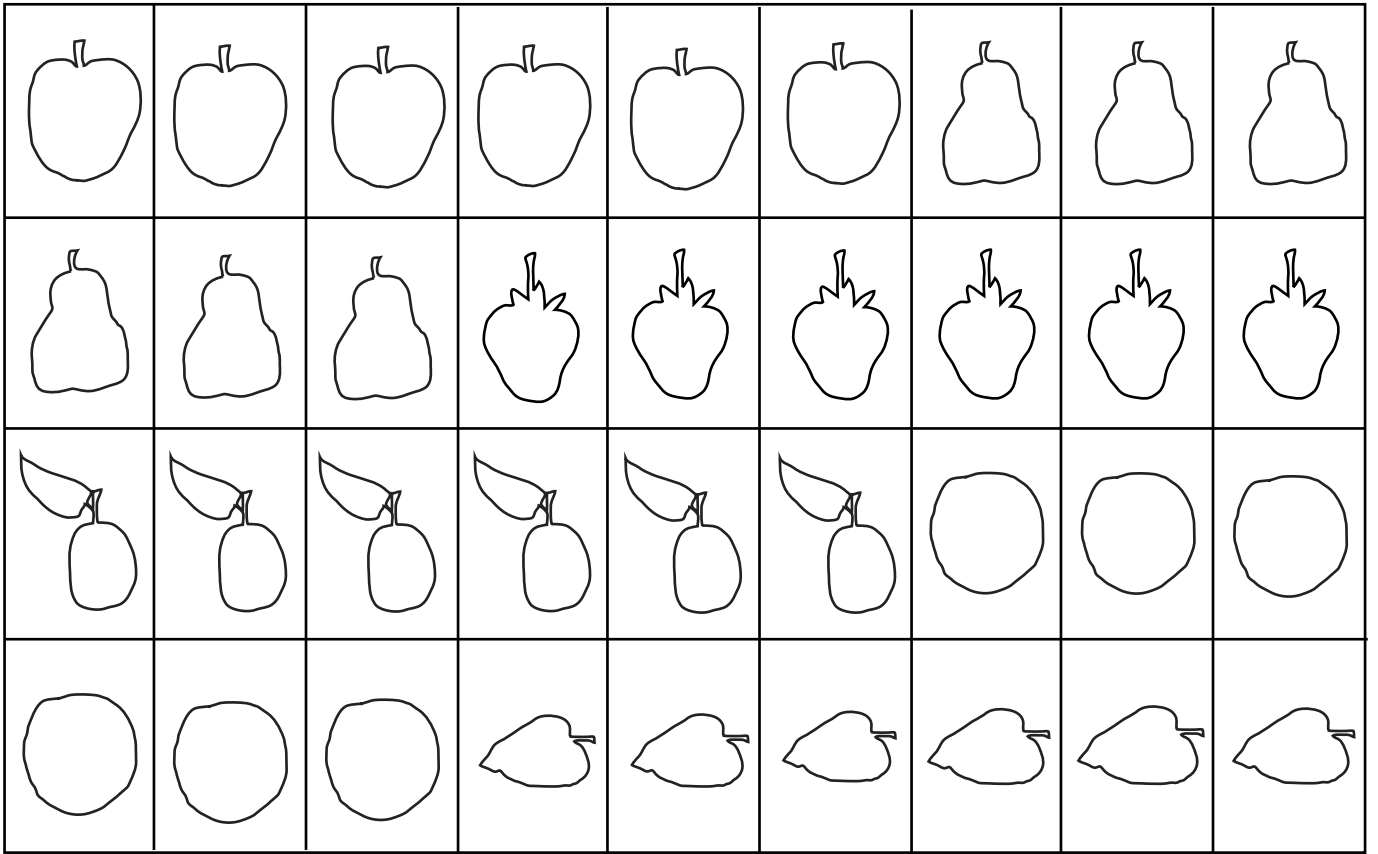

MUNDUAREN EZAGUTZA

Beldarraren aldaketa : irudiak ordenan ezar itzazu.

Pinpirinak arroltzeak hosto baten gainean erruten ditu.	Arroltzetik, beldar ñimiño bat jalgitzen da. Gose da eta hostoak jaten ditu. Anitz jaten du.	Handitu eta gizendu ondoan, beldarra kuskuan kurubilkatzen da.	Bizpahiru asteren buruan, kuskutik pinpirin eder bat jalgitzen da.

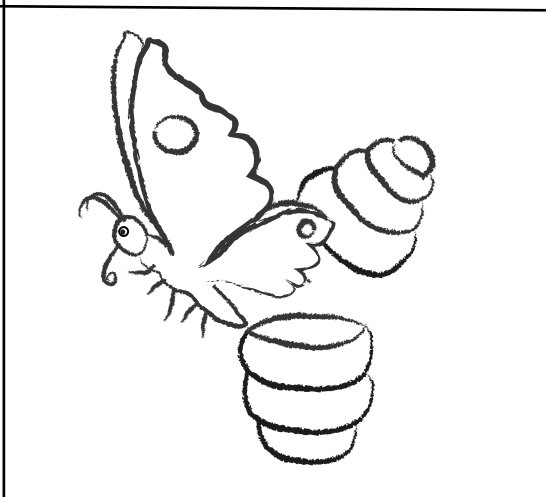
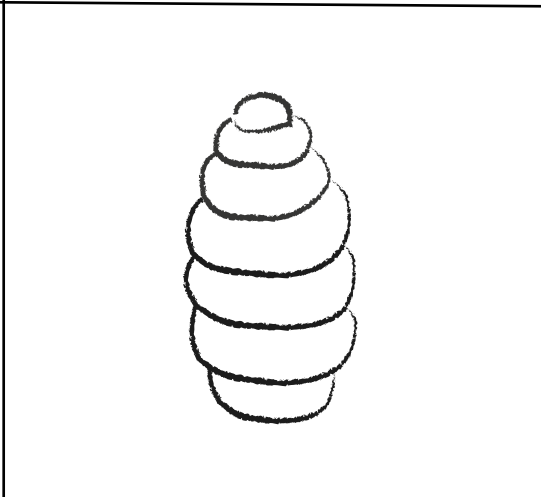
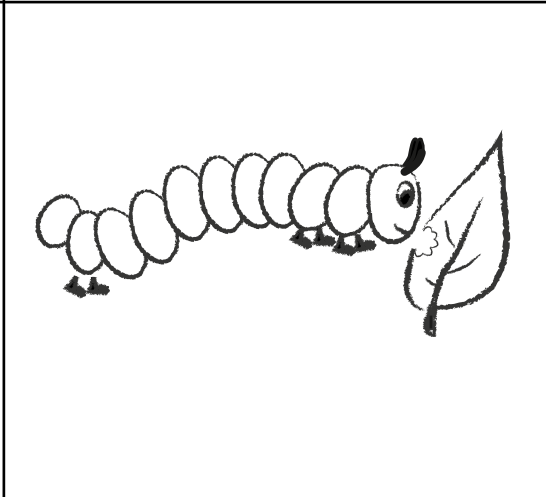
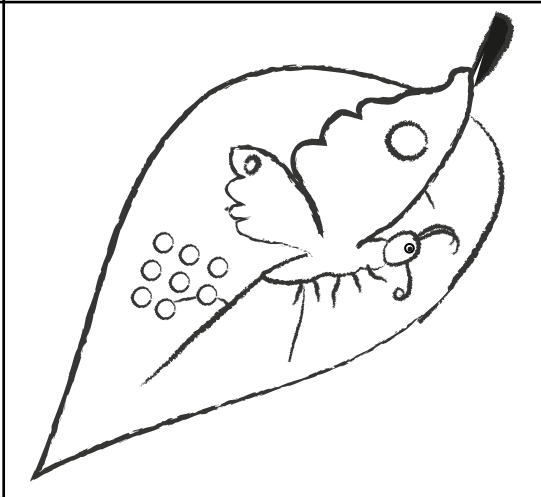
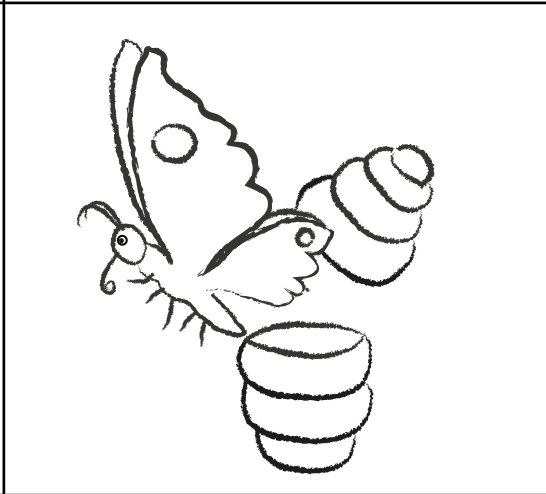
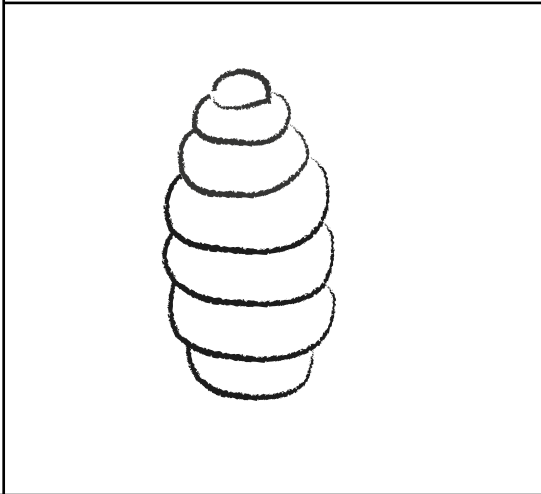
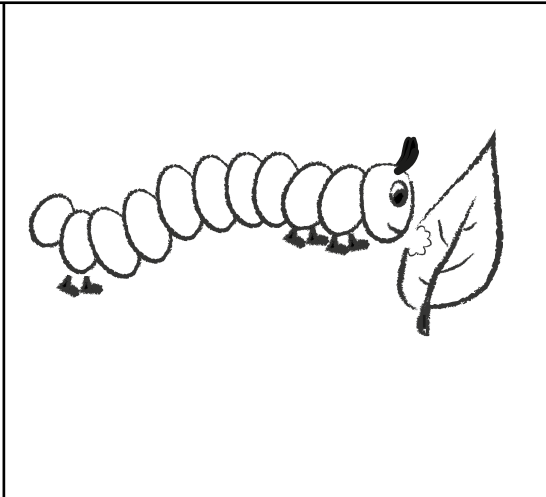
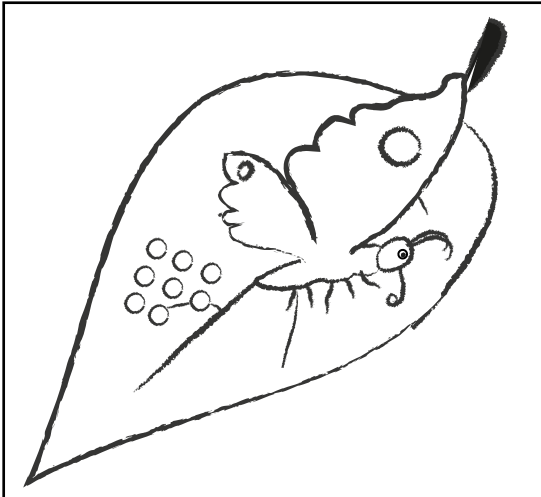

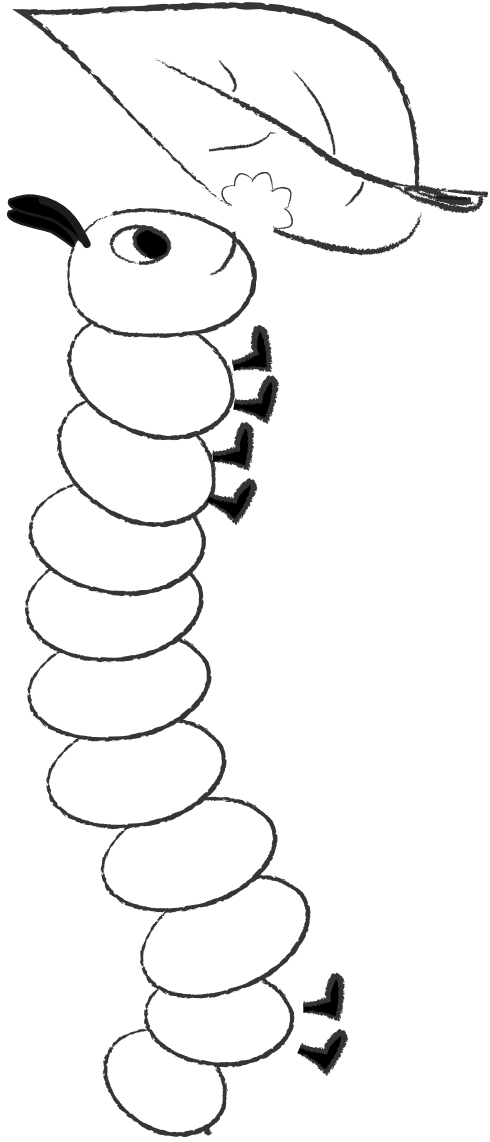

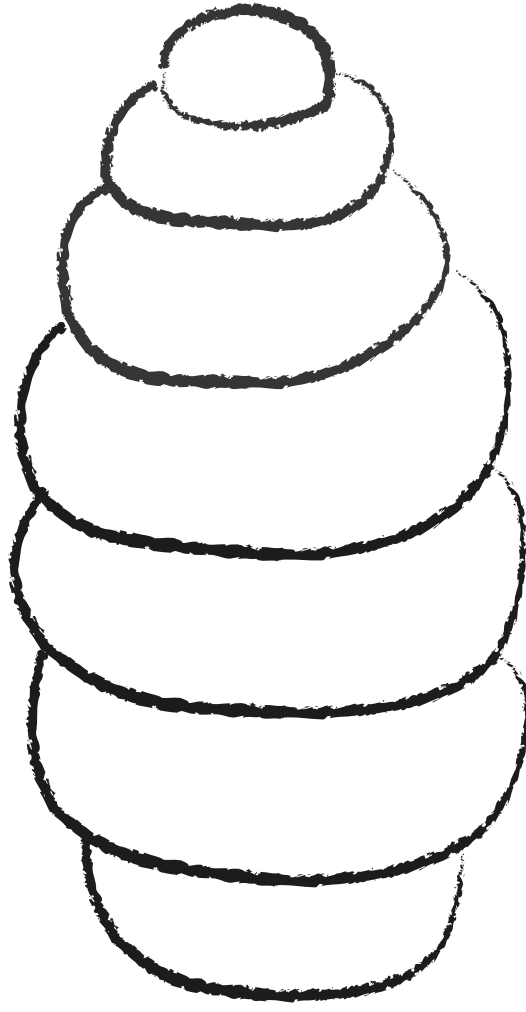

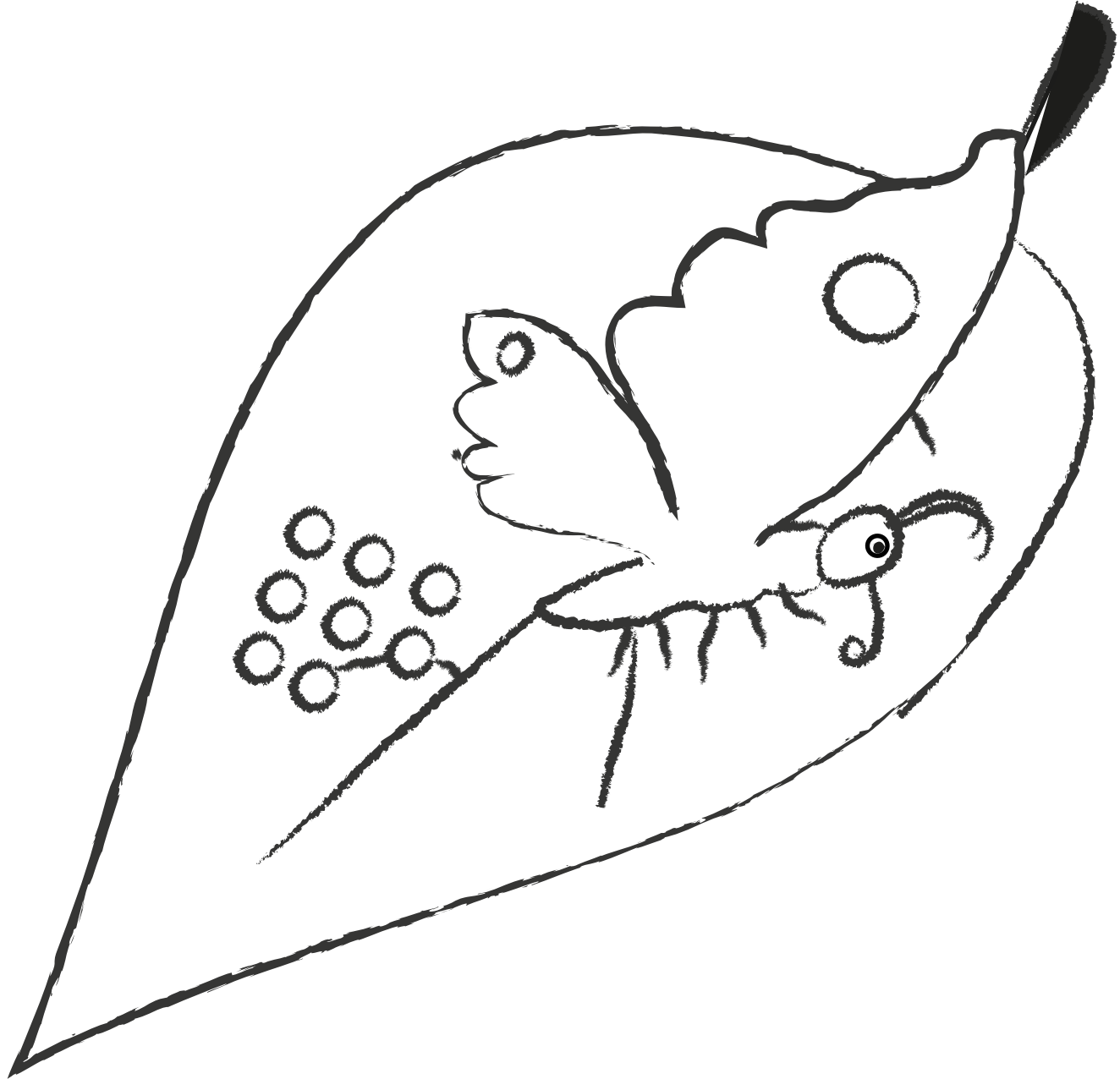

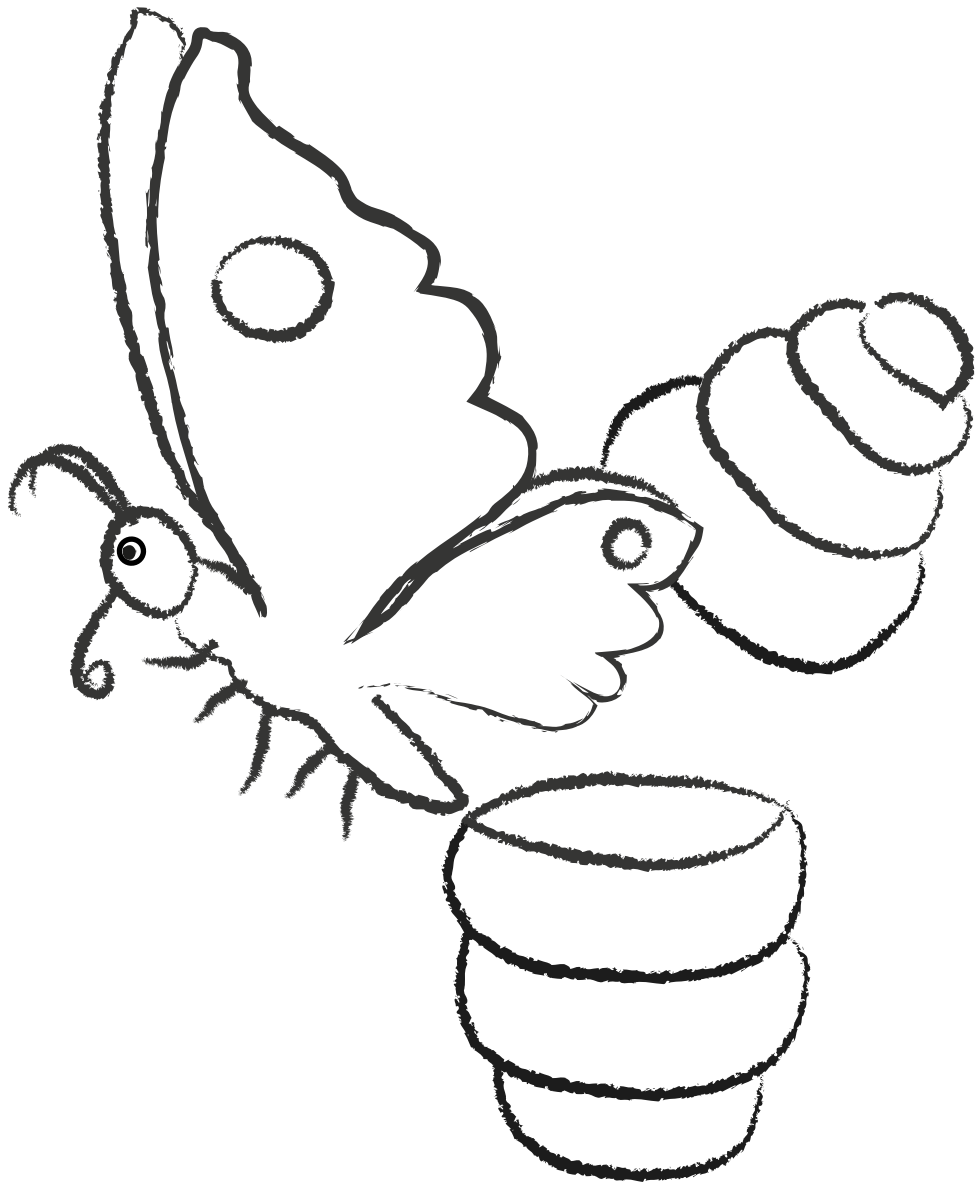

Laukitxo bakoitzean den zenbakiari so egin eta, beldar kopuru egokia kola ezazu.

3

2

1

3

2

1

3

2

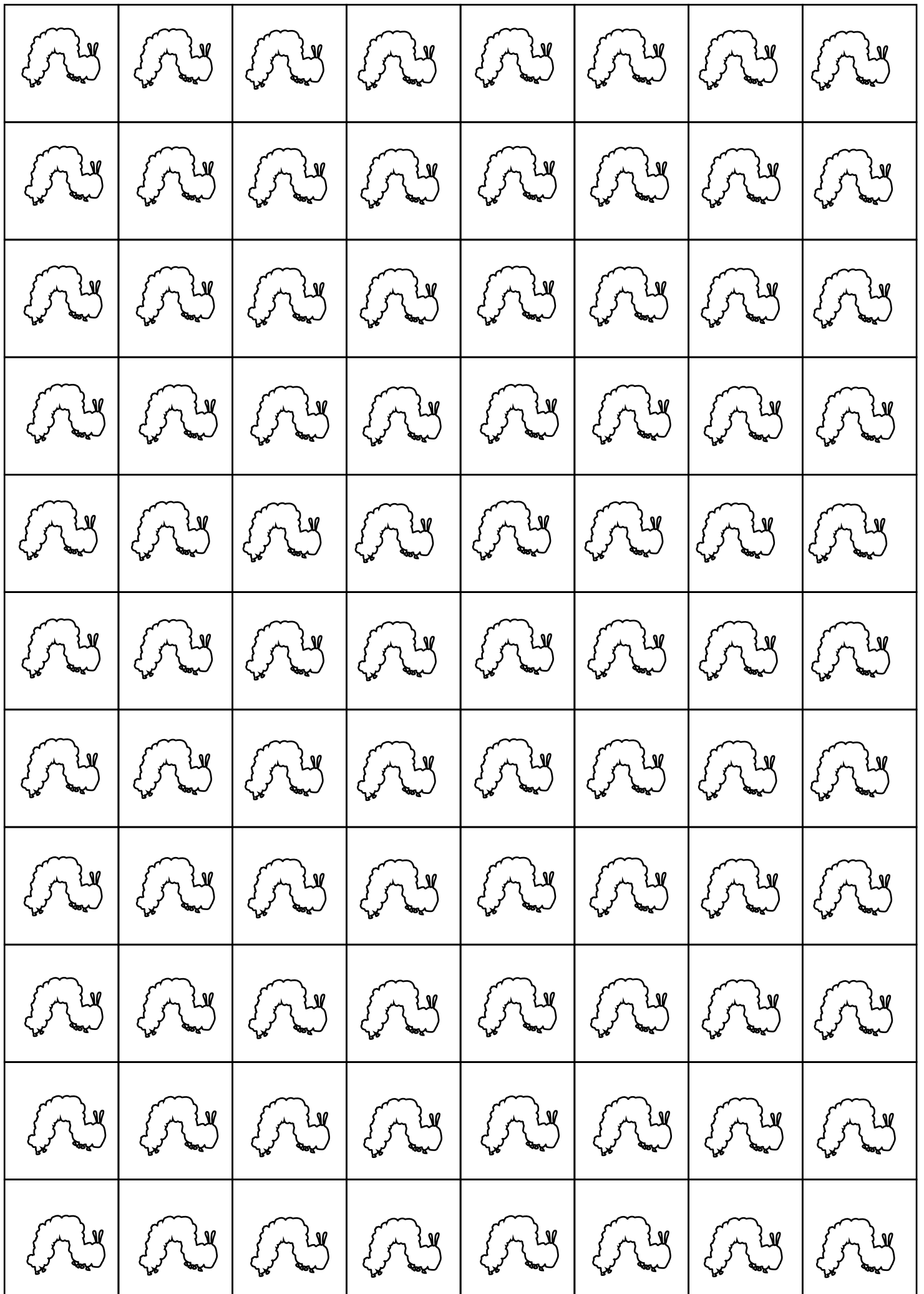

Testua irakur
eta zakuan kola
itzazu beldarrak
zilatu dituen
fruituak.

Harrak jan du :

- laranja bat
- bi sagar
- marrubi bat
- lau aran
- bost udare

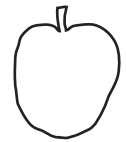
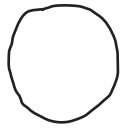
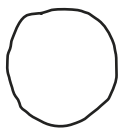
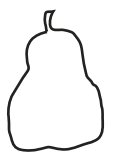
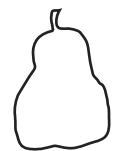
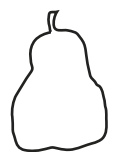
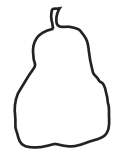
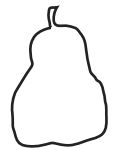
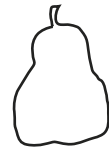
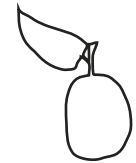
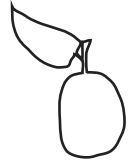
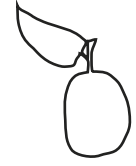
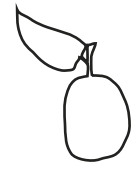
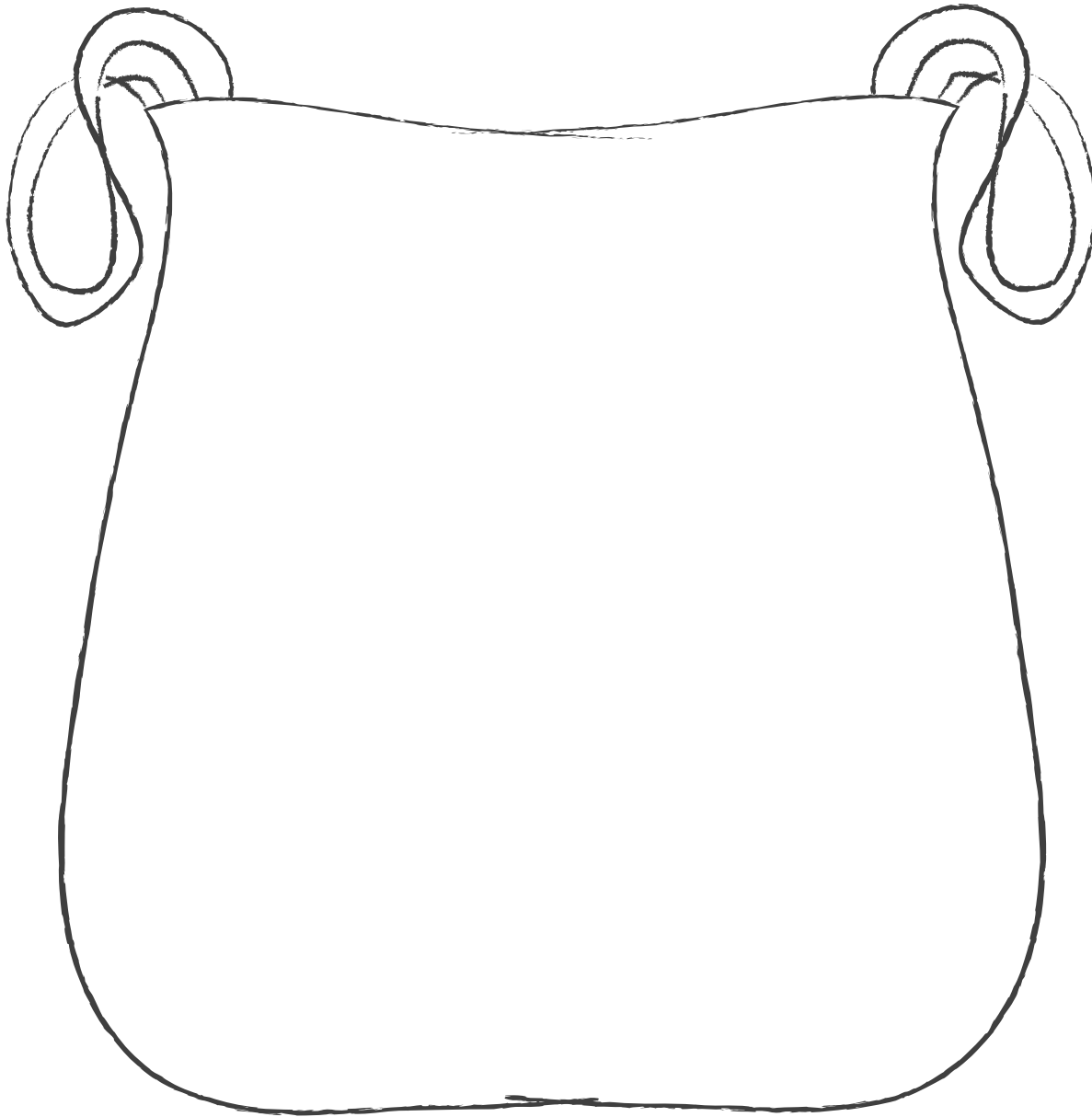

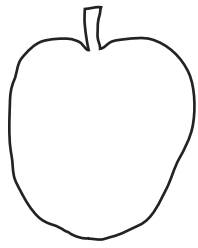

sagar

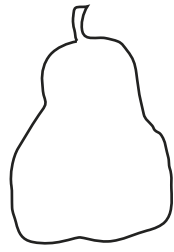

udare

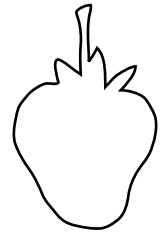

marrubi

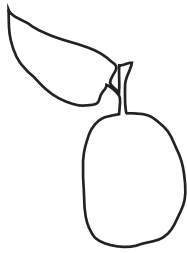

aran

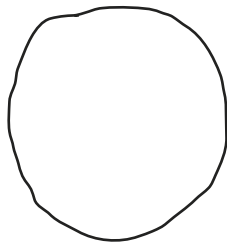

laranja

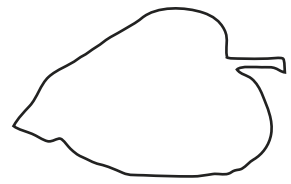

hostoa

1

bat

2

bi

3

hiru

4

lau

5

bost

6

sei